



Series 45
G Frame

Technical
Information

Phased Out Product

FRAME G

Design	4
Specifications.....	5
Performance G74B.....	6
Performance G90C.....	7
Order code.....	8
Controls.....	10
Pressure compensated control (PC)	10
Remote PC control (RP).....	10
Load sensing control (LS).....	11
Load sensing control with internal bleed orifice (LB)	11
Input shafts.....	12
Auxiliary mounting pads	13
SAE-A auxiliary mounting pad.....	13
SAE-B auxiliary mounting pad	13
Displacement limiter.....	14
SAE-C auxiliary mounting pad.....	14
Installation drawings.....	15
Running cover.....	15
Adjustable displacement limiter.....	15
Axial ported endcap	16
Radial ported endcap.....	18

Series 45 G Frame Pumps
Technical Information
General information

This information was removed from:

Series 45 Axial Piston Open Circuit Pumps Technical Information Manual **520L0519**

Rev E November 2006

For more information regarding the Series 45 product line refer to the current version of **520L0519**.

Phase 2
Open Circuit Product

DESIGN

Series 45 Frame G pumps have a dual servo piston design with a cradle-type swashplate set in polymer-coated journal bearings. The bias piston increases swashplate angle. The displacement piston decreases swashplate angle. At equal pressure, the larger diameter displacement piston overpowers the bias piston. Nine reciprocating pistons displace fluid from the pump inlet to the pump outlet as the cylinder block rotates on the pump input shaft. The block spring holds the piston slippers to the swashplate via the slipper retainer. The cylinder block rides on a bi-metal valve plate optimized for high volumetric efficiency and low noise. Tapered roller bearings support the input shaft and a viton lip-seal protects against shaft leaks.

An adjustable one spool (PC only, not shown) or two spool (LS) control senses system pressure and load pressure (LS controls). The control ports system pressure to the displacement piston to control pump output flow.

Frame G cross section

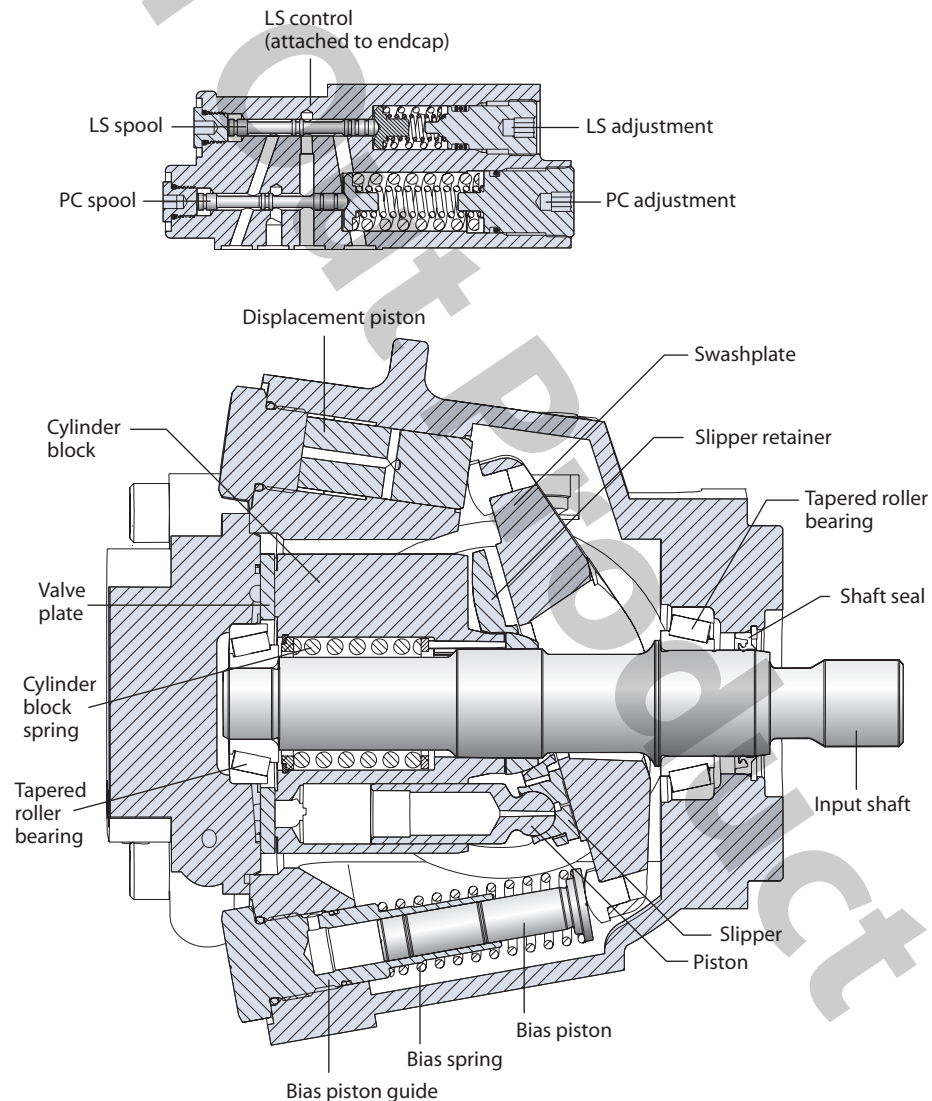

P104 002E

SPECIFICATIONS

For general operating parameters, including fluid viscosity, temperature, and inlet and case pressures, [see page 13](#). For system design parameters, including installation, filtration, reservoir, and line velocities, [see page 15](#).

Features and options

Feature		Unit	Model	
			G74B	G90C
Maximum Displacement		cm ³ [in ³]	74 [4.52]	90 [5.49]
Flow at rated speed (theoretical)		l/min [US gal/min]	177.6 [46.9]	198 [52.3]
Input torque at maximum displacement (theoretical)		N•m/bar [lbf•in/1000 psi]	1.178 [719]	1.432 [874]
Mass moment of inertia of internal rotating components		kg•m ² [slug•ft ²]	0.00630 [0.00465]	0.00650 [0.00480]
Weight	Axial ports	kg [lb]	29 [63]	
	Radial ports		36 [80]	
Rotation			Clockwise, Counterclockwise	
Mounting			SAE-C	
Auxiliary mounting (See page 74)			SAE-A, SAE-B, SAE-BB, SAE-C	
System ports (type)			4-bolt split flange	
System ports (location)			Axial, Radial	
Control types (See page 71)			PC, Remote PC, LS, LS with internal bleed	
Shafts (See page 73)	Splined		14 tooth, 17 tooth	
	Straight		Ø 31.75 mm [1.25 in]	
Displacement limiters (See page 75)			Optional, adjustable	

For definitions of pressure and speed ratings, [see page 14](#). For more information on external shaft loads, [see page 16](#); mounting flange loads, [see page 17](#).

Ratings

Rating			Units		Model	
			G74B	G90C		
Input speed ¹	minimum	min ⁻¹ (rpm)	500	500		
	continuous		2400	2200		
	maximum		2800	2600		
Working pressure	continuous	bar [psi]	310 [4495]	260 [3770]		
	maximum		400 [5800]	350 [5075]		
External shaft loads	External moment (M _e)	N•m [lbf•in]	300 [2655]			
	Thrust in (T _{in}), out (T _{out})	N [lbf]	2900 [650]			
Bearing life	at 140 bar [2030 psi]	B ₁₀ hours	41 383	19 847		
	at 210 bar [3045 psi]		9048	4339		
	at 260 bar [3770 psi]		4062	1948		
	at 310 bar [4495 psi]		2101	—		
Mounting flange load moments	Vibratory (continuous)	N•m [lbf•in]	1580 [14 000]			
	Shock (max)		5650 [50 000]			

1. Input speeds are valid at 1 bar absolute [0 in Hg vac] inlet pressure. See [Inlet pressure vs. speed](#) charts.

Sound levels²

For more information on noise levels, [see page 19](#).

dB(A)	210 bar [3045 psi]		260 bar [3770 psi]		310 bar [4495 psi]		
	Model	1800 min ⁻¹ (rpm)	Rated speed	1800 min ⁻¹ (rpm)	Rated speed	1800 min ⁻¹ (rpm)	Rated speed
G74B		75	78	74	76	75	77
C90C		74	76	75	77	—	—

2. Sound data was collected in a *semi-anechoic* chamber. Values have been adjusted (-3 dB) to reflect *anechoic* levels.

PERFORMANCE
G74B

Flow and power data valid at 49°C [120°F] and viscosity of 17.8 mm²/sec [88 SUS].

Flow vs. speed

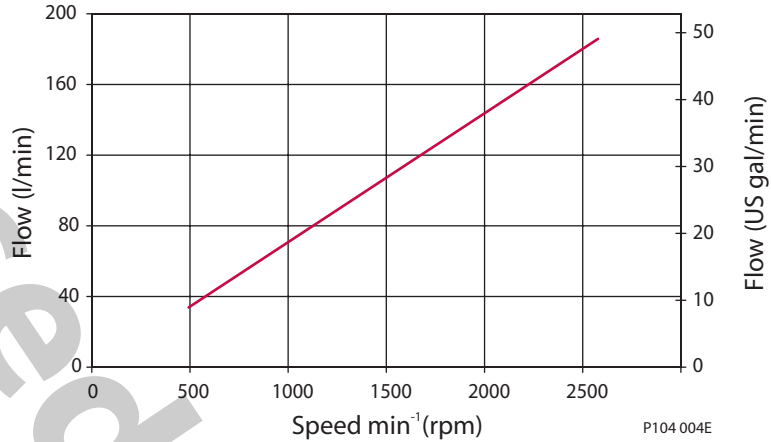

Input power vs. speed

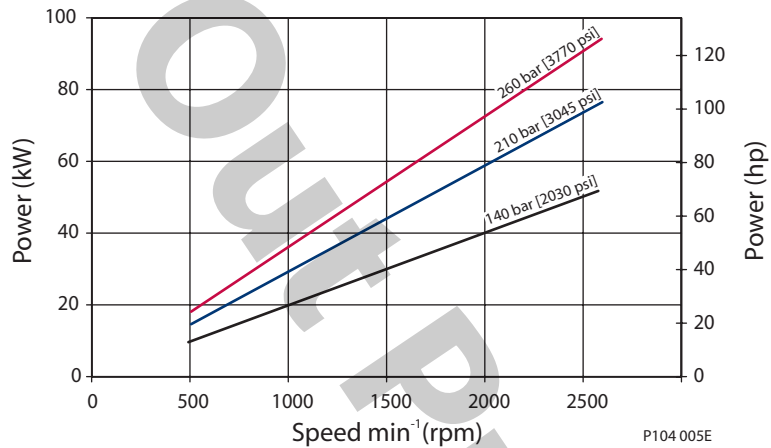

Inlet pressure vs. speed

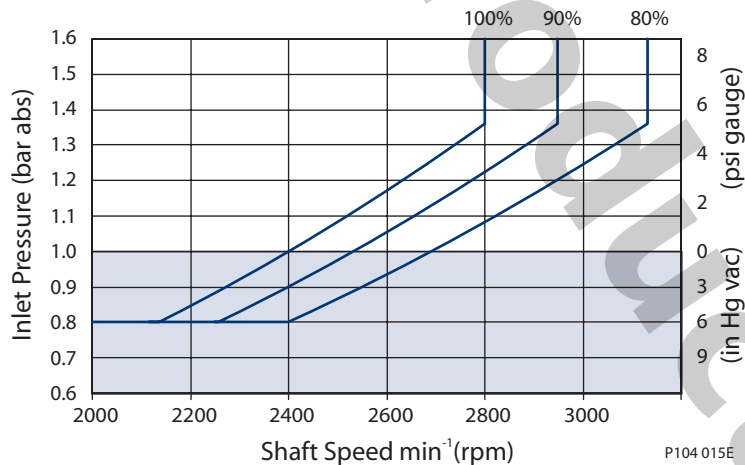

The chart on the right shows allowable inlet pressure and speed at various displacements. Greater speeds and lower inlet pressures are possible at reduced displacement. Operating outside of acceptable limits reduces pump life.

**PERFORMANCE
 G90C**

Flow and power data valid at 49°C [120°F] and viscosity of 17.8 mm²/sec [88 SUS].

Flow vs. speed

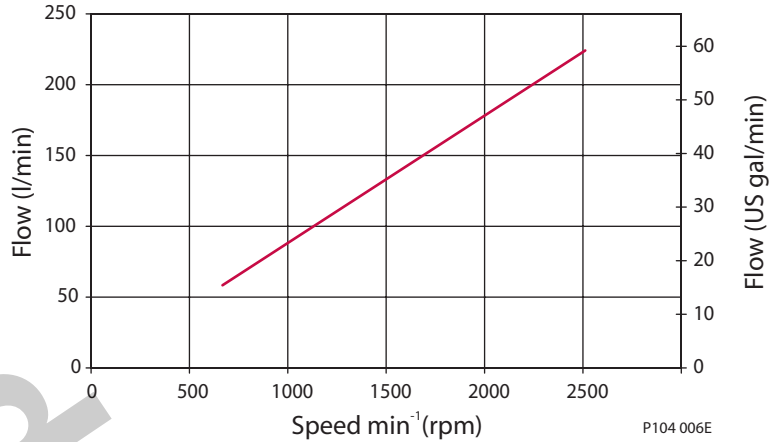

Input power vs. speed

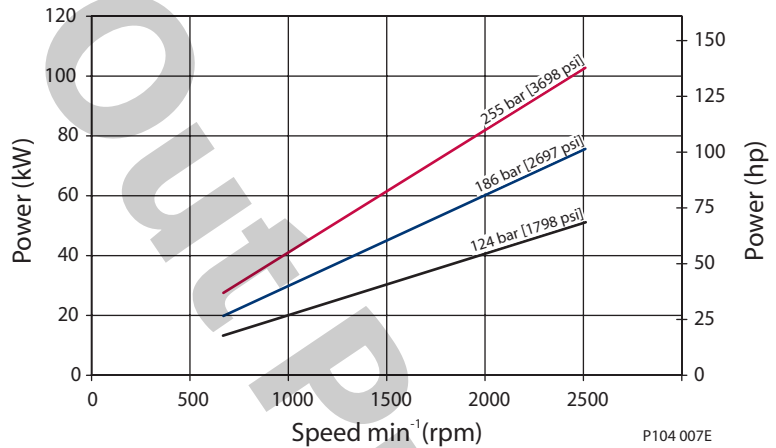

Inlet pressure vs. speed

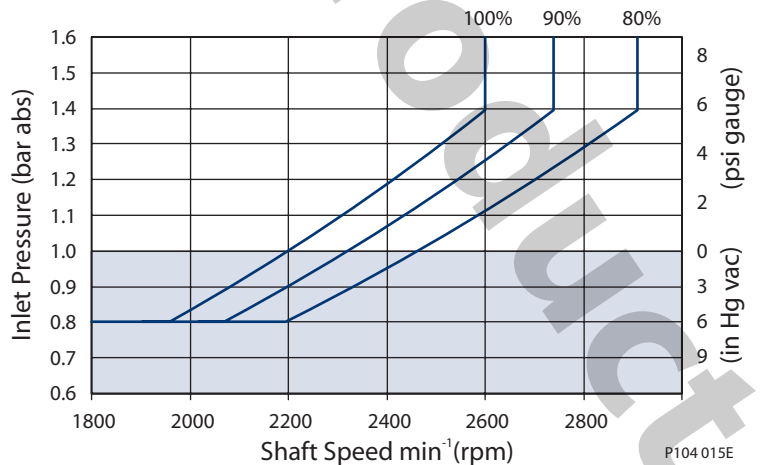

The chart on the right shows allowable inlet pressure and speed at various displacements. Greater speeds and lower inlet pressures are possible at reduced displacement. Operating outside of acceptable limits reduces pump life.

ORDER CODE

R
S
P
C
D
E
F
G
H
-

1
2
3

1
2
3
-
L
M
N

R Product

GR	G Frame, variable displacement open circuit pump
-----------	--

S Rotation

L	Left hand (counterclockwise)
R	Right hand (clockwise)

P Displacement and pressure rating

074B	074 cm ³ /rev [4.52 in ³ /rev], 310 bar [4495 psi] continuous working pressure
090C	090 cm ³ /rev [5.49 in ³ /rev], 260 bar [3770 psi] continuous working pressure

C Control type

PC	Pressure compensated control 100-280 bar [1450-4060 psi]
BC	Pressure compensated control 290-310 bar [4205-4495 psi]
RP	Remote pressure compensated control 100-280 bar [1450-4060 psi]
BP	Remote pressure compensated control 290-310 bar [4205-4495 psi]
LS	Load sensing / pressure compensating control 100-280 bar [1450-4060 psi]
BS	Load sensing / pressure compensating control 290-310 bar [4205-4495 psi]
LB	Load sensing / pressure compensating control with internal bleed orifice 100-280 bar [1450-4060 psi]
BB	Load sensing / pressure compensating control with internal bleed orifice 290-310 bar [4205-4495 psi]

D PC setting (2 digit code, 10 bar increments)

Example	10 = 100 bar
10-31	100 to 310 bar [1450 to 4495 psi] (074B)
10-26	100 to 260 bar [1450 to 3770 psi] (090C)

E Load sensing setting (2 digit code, 1 bar increments)

Example	20 = 20 bar
10-30	10 to 40 bar [145 to 435 psi]
NN	Not applicable (use with PC controls)

F Not used

NN	Not applicable
-----------	----------------

ORDER CODE
 (continued)



G Pilot orifice

N	Standard
----------	----------

H Gain orifice

3	Standard
----------	----------

J1 Input shaft

S1	14 tooth, 12/24 pitch (ANSI B92.1 1970 - Class 5)
S2	17 tooth, 12/24 pitch (ANSI B92.1 1970 - Class 5)
K4	Ø 31.75 mm [1.25 in], straight keyed

J2 Auxiliary mounting flange

N	None
A	SAE-A, 9-tooth coupling
T	SAE-A, 11-tooth coupling
B	SAE-B, 13-tooth coupling
V	SAE-BB, 15-tooth coupling
C	SAE-C, 14-tooth coupling

J3 System port size and location

Code	Location	Port type	Inlet size	Outlet size
2	Radial	4-bolt split-flange	2 in.	1 in.
4	Axial	4-bolt split-flange	2 in.	1 in.

K1 Shaft seal

A	Single lip seal, viton
----------	------------------------

K2 Mounting flange and housing port style

1	SAE-C 4-bolt, SAE O-ring boss housing ports
----------	---

K3 Not used

N	Not applicable
----------	----------------

L Displacement limiter

NNN	None
AAA	Adjustable, factory set at max angle (074B)
CAA	Adjustable, factory set at max angle (090C)

M Special hardware

NNN	None
------------	------

N Special features

NNN	None
------------	------

CONTROLS

Pressure compensated control (PC)

Specifications **PC control setting range**

Model	bar	psi
G74B	100–310	1450–4495
G90C	100–260	1450–3770

*Response/recovery times**

(ms)	Response	Recovery
G74B	35	130
G90C	40	140

* For definitions, *see page 9.*

Schematic diagram **PC schematic**

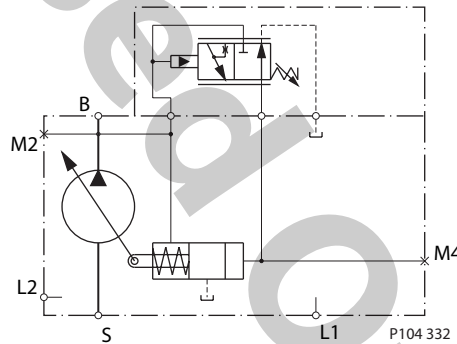

Legend

- B = Outlet
- S = Inlet
- L1, L2 = Case drain
- M2 = System pressure gauge port
- M4 = Servo pressure gauge port

Remote PC control (RP)

Specifications **PC control setting range**

Model	bar	psi
G74B	100–310	1450–4495
G90C	100–260	1450–3770

*Response/recovery times**

(ms)	Response	Recovery
G74B	35	130
G90C	40	140

* For definitions, *see page 10.*

Schematic diagram **Remote PC schematic**

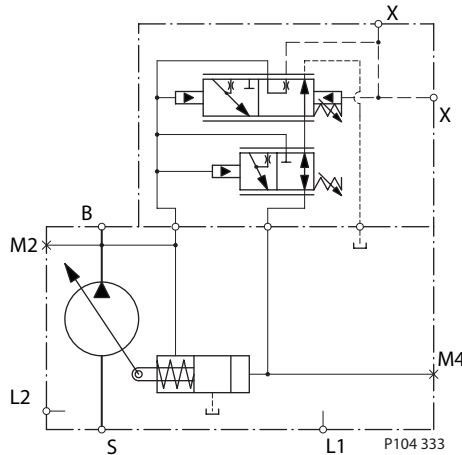

Legend

- B = Outlet
- S = Inlet
- L1, L2 = Case drain
- M2 = System pressure gauge port
- M4 = Servo pressure gauge port
- X = Remote PC port

CONTROLS
 (continued)

Load sensing control (LS)

Specifications *PC setting range*

Model	bar	psi
G74B	100–310	1450–4495
G90C	100–260	1450–3770

*Response/recovery times**

(ms)	Response	Recovery
G74B	35	100
G90C	40	130

* For definitions, see page 11

Schematic diagram *LS Schematic*

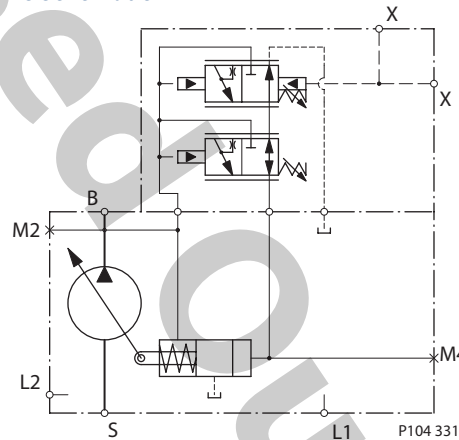

LS setting range

Model	bar	psi
All	10–30	145–435

Legend

- B = Outlet
- S = Inlet
- L1, L2 = Case drain
- M2 = System pressure gauge port
- M4 = Servo pressure gauge port
- X = LS signal port

Load sensing control with internal bleed orifice (LB)

Specifications *PC setting range*

Model	bar	psi
G74B	100–310	1450–4495
G90C	100–260	1450–3770

*Response/recovery times**

(ms)	Response	Recovery
G74B	35	100
G90C	40	130

* For definitions, see page 11.

Schematic diagram *LB Schematic*

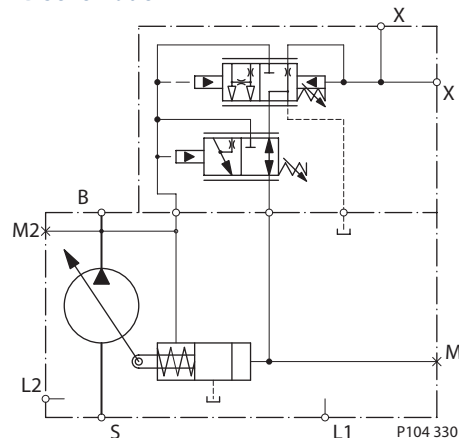

LS setting range

Model	bar	psi
All	10–30	145–435

Legend

- B = Outlet
- S = Inlet
- L1, L2 = Case drain
- M2 = System pressure gauge port
- M4 = Servo pressure gauge port
- X = LS signal port

INPUT SHAFTS

Shaft data

Code	Description	Maximum torque rating ¹ N·m [lbf·in]	Drawing
S1	14 tooth spline 12/24 pitch (ANSI B92.1 1970 - Class 5)	734 [6500]	
S2	17 tooth spline 12/24 pitch (ANSI B92.1 1970 - Class 5)	1017 [9000]	
K4	Ø 31.75 mm [1.25 in] Straight keyed	734 [6495]	

1. See *Input shaft torque ratings*, page 18 for an explanation of maximum torque.

AUXILIARY MOUNTING PADS

See page 18 for mating pump pilot and spline dimensions.

SAE-A auxiliary mounting pad
 Dimensions

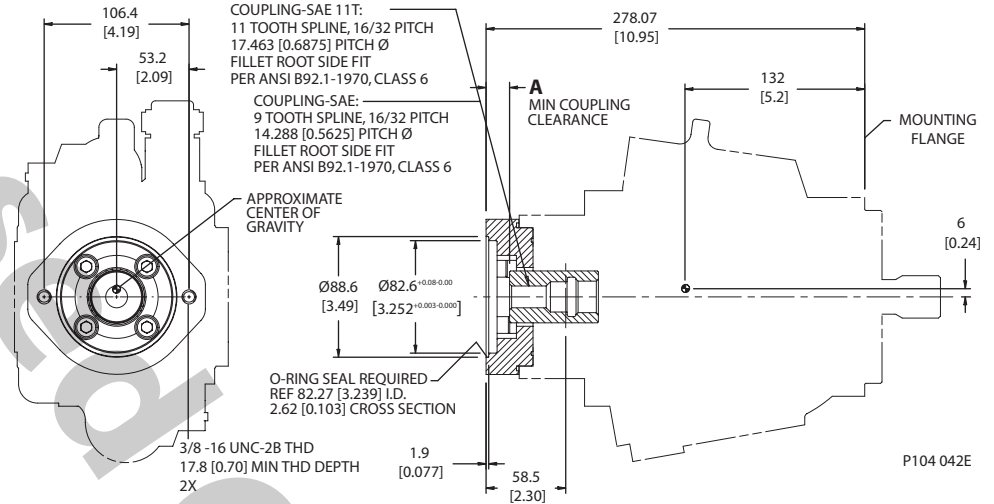

Specifications

Coupling	9-tooth	11-tooth
Spline minimum engagement	13.5 mm [0.53 in]	15 mm [0.59 in]
Maximum torque	107 N·m [950 lbf·in]	147 N·m [1300 lbf·in]
Dimension A	21.1 mm [0.83 in]	16.1 mm [0.63 in]

SAE-B auxiliary mounting pad
 Dimensions

See page 18 for mating pump pilot and spline dimensions.

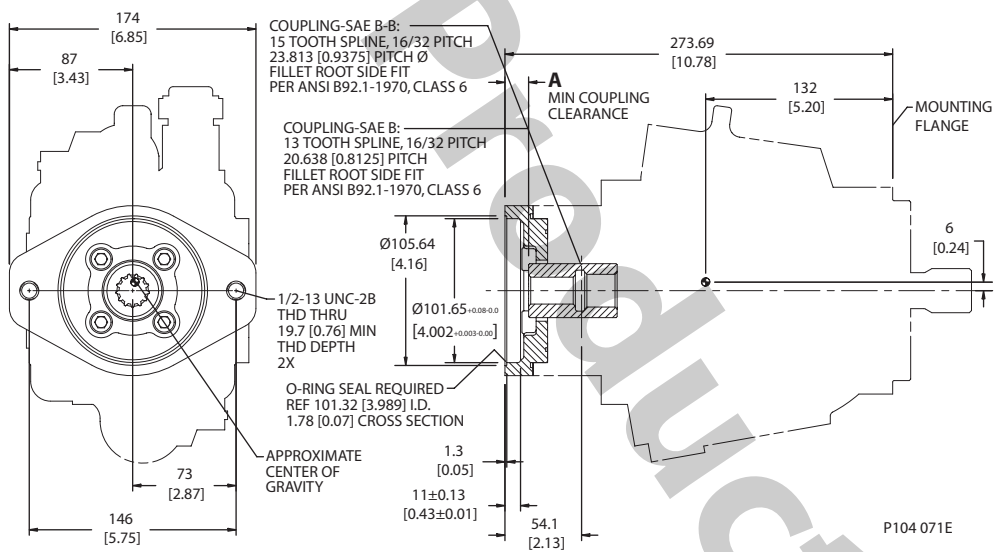

Specifications

Coupling	13-tooth	15-tooth
Spline minimum engagement	14.2 mm [0.56 in]	18.9 mm [0.74 in]
Maximum torque	249 N·m [2200 lbf·in]	339 N·m [3000 lbf·in]
Dimension A	20.7 mm [0.81 in]	12.7 mm [0.5 in]

AUXILIARY MOUNTING PADS (continued)

SAE-C auxiliary mounting pad
 Dimensions

See page 18 for mating pump pilot and spline dimensions.

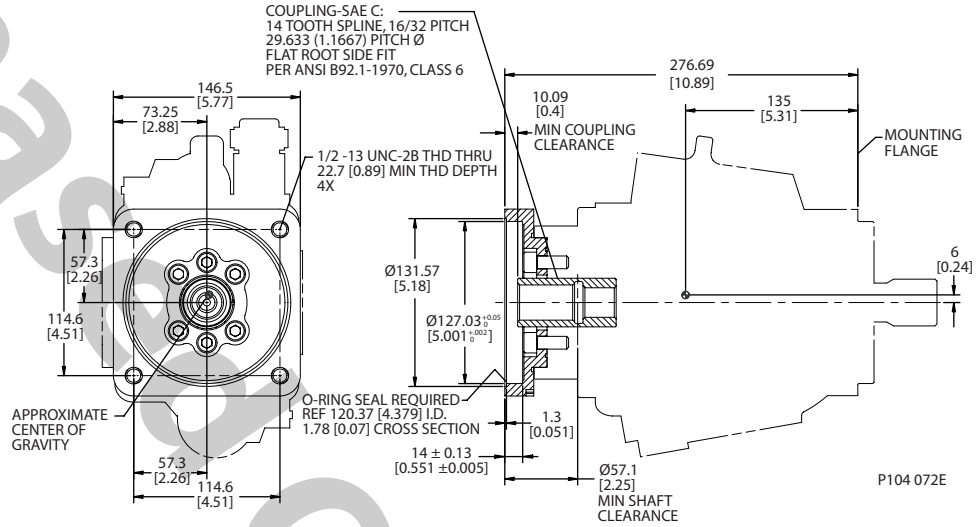

Specifications

Coupling	14-tooth
Spline minimum engagement	18.3 mm [0.72 in]
Maximum torque	339 N·m [3000 lbf·in]

DISPLACEMENT LIMITER

G Frame open circuit pumps are available with an optional adjustable displacement limiter. This adjustable stop limits the pump's maximum displacement.

Displacement limiter cross-section

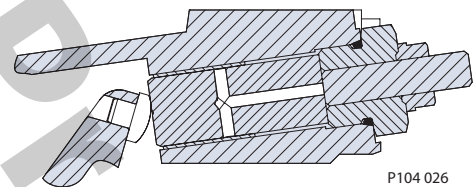

P104 026

Setting range

G74B	56 to 74 cm ³ [3.39 to 4.52 in ³]
G90C	68 to 90 cm ³ [4.12 to 5.49 in ³]

1. See *Input shaft torque ratings*, page 19 for definitions of continuous and maximum torque.

**INSTALLATION
DRAWINGS**

Running cover
Dimensions

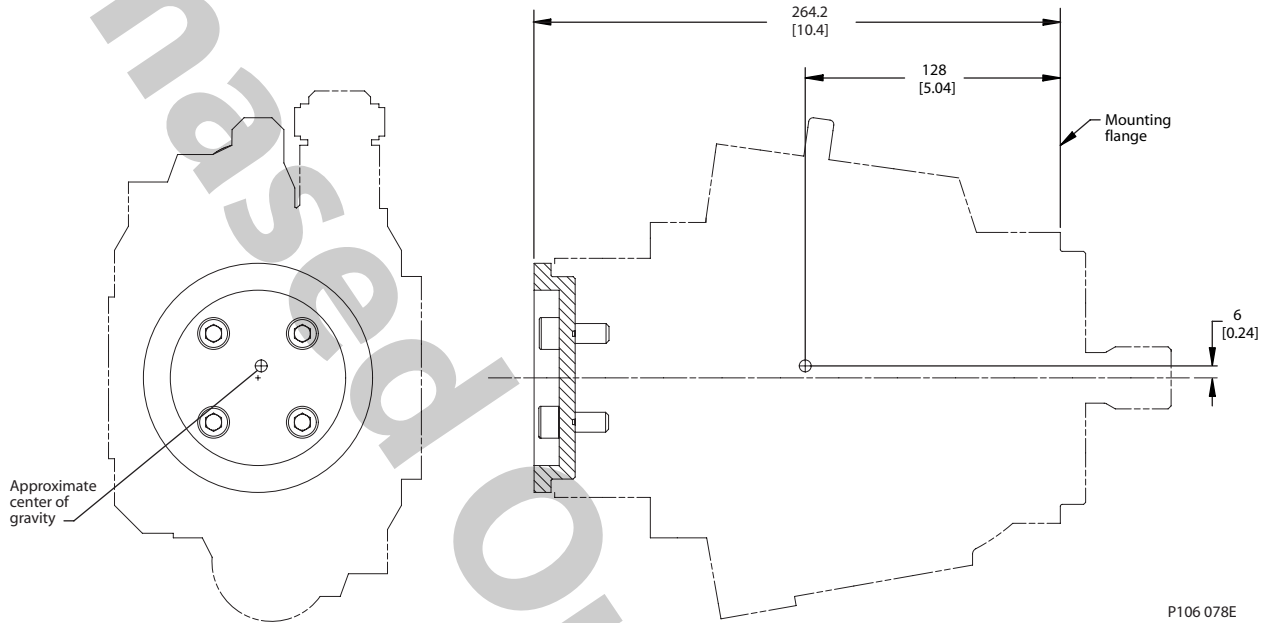

Adjustable displacement limiter
Dimensions

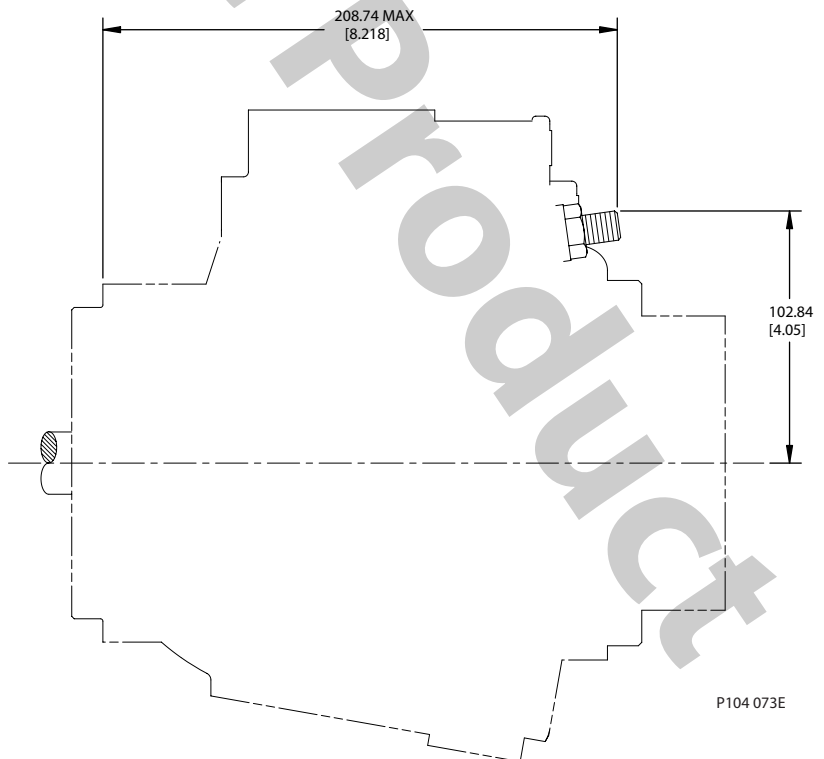

INSTALLATION DRAWINGS (continued)

Axial ported endcap

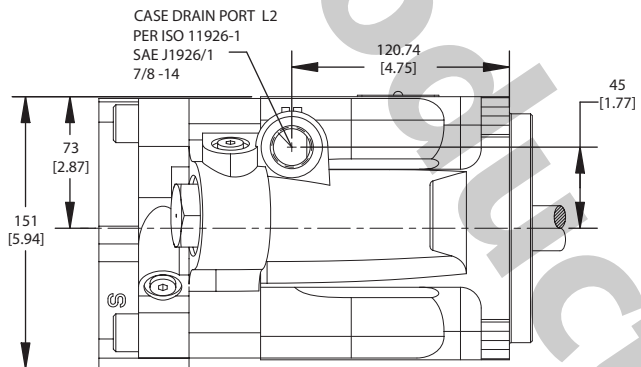
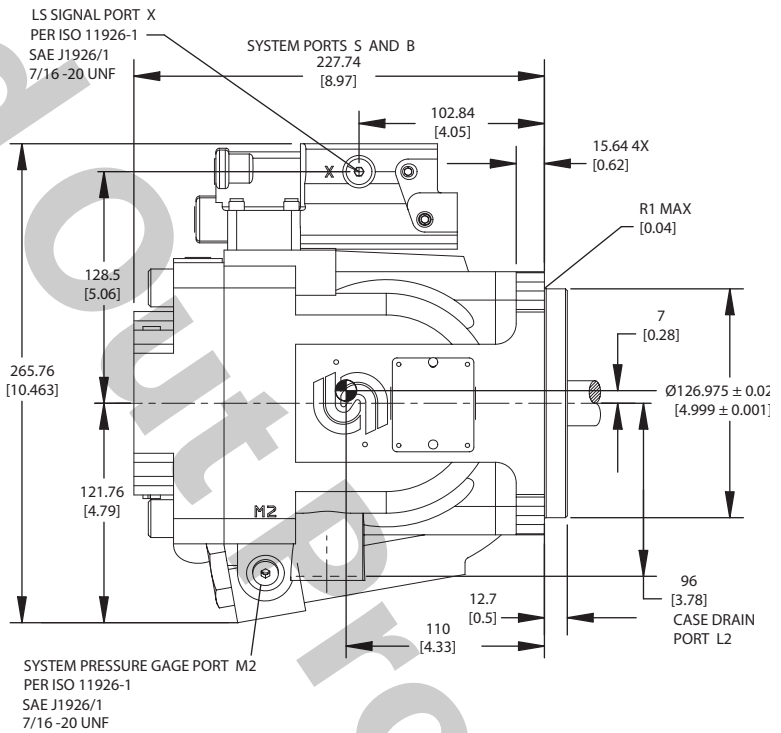
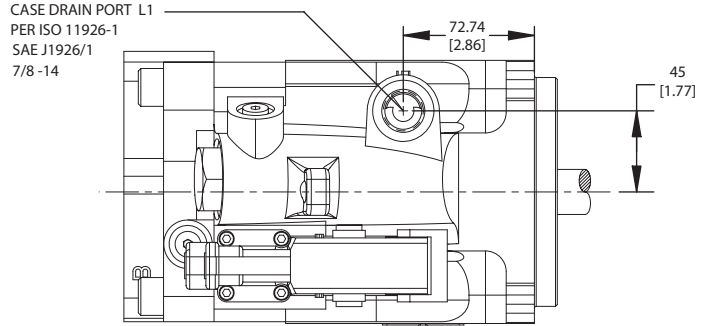
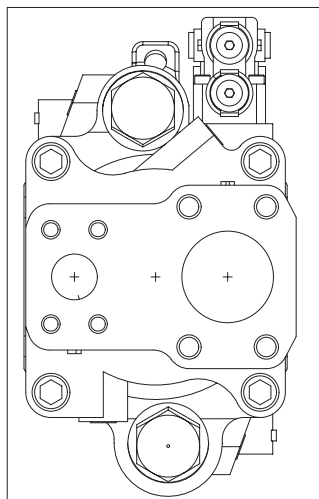
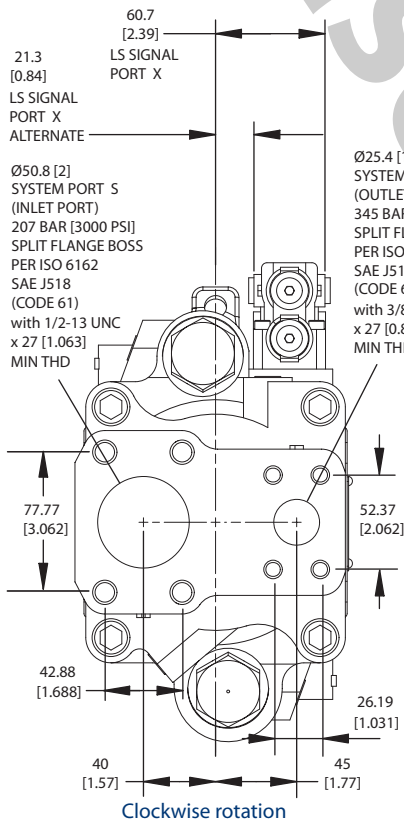

P106 174E



**INSTALLATION
DRAWINGS
(continued)**

Axial ported endcap (continued)

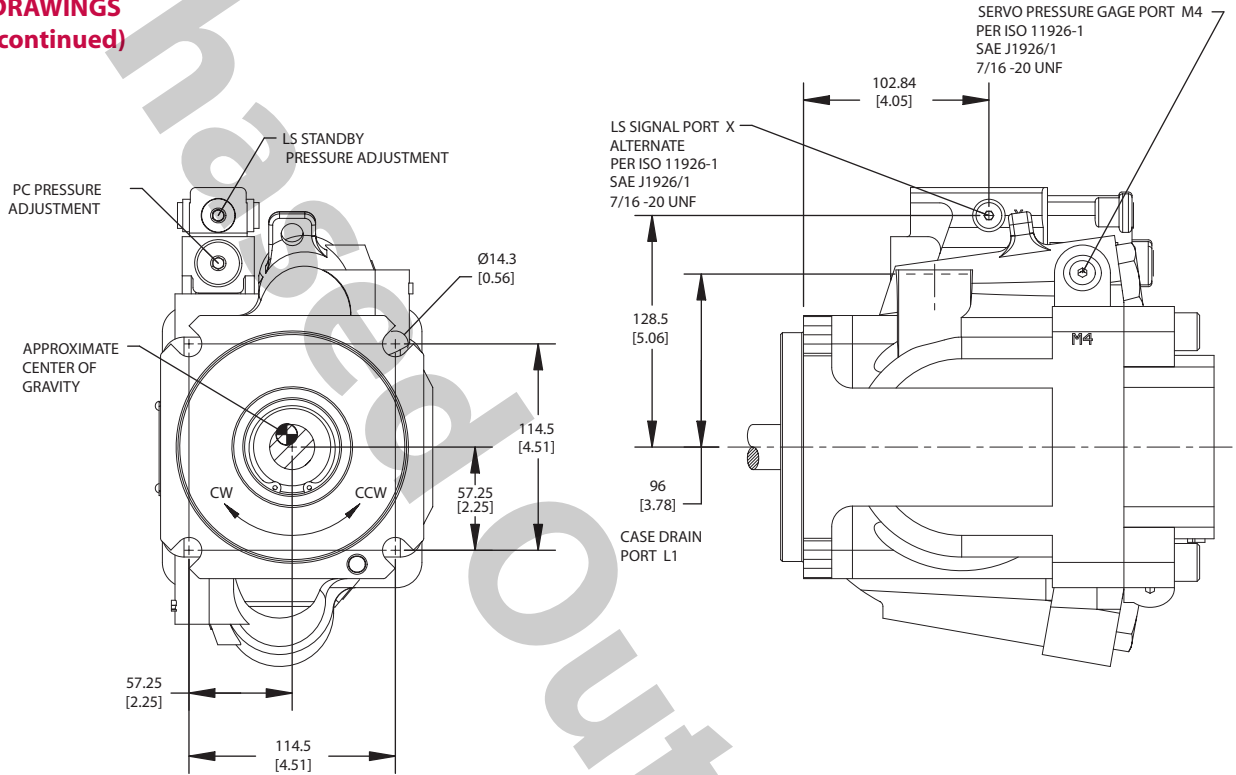

P104 074E



**INSTALLATION
DRAWINGS
(continued)**

Radial ported endcap

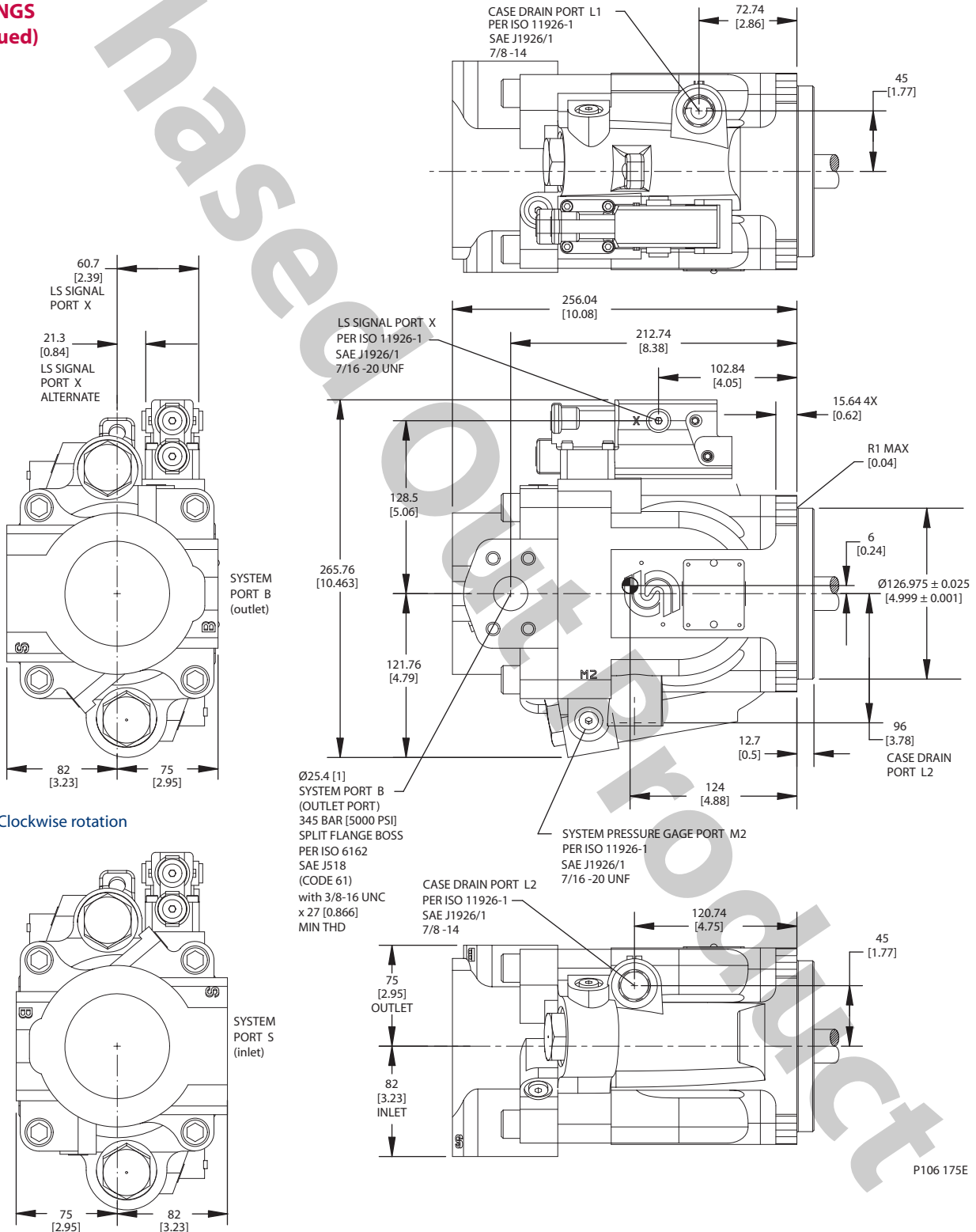

P106 175E



**INSTALLATION
DRAWINGS
(continued)**

Radial ported endcap (continued)

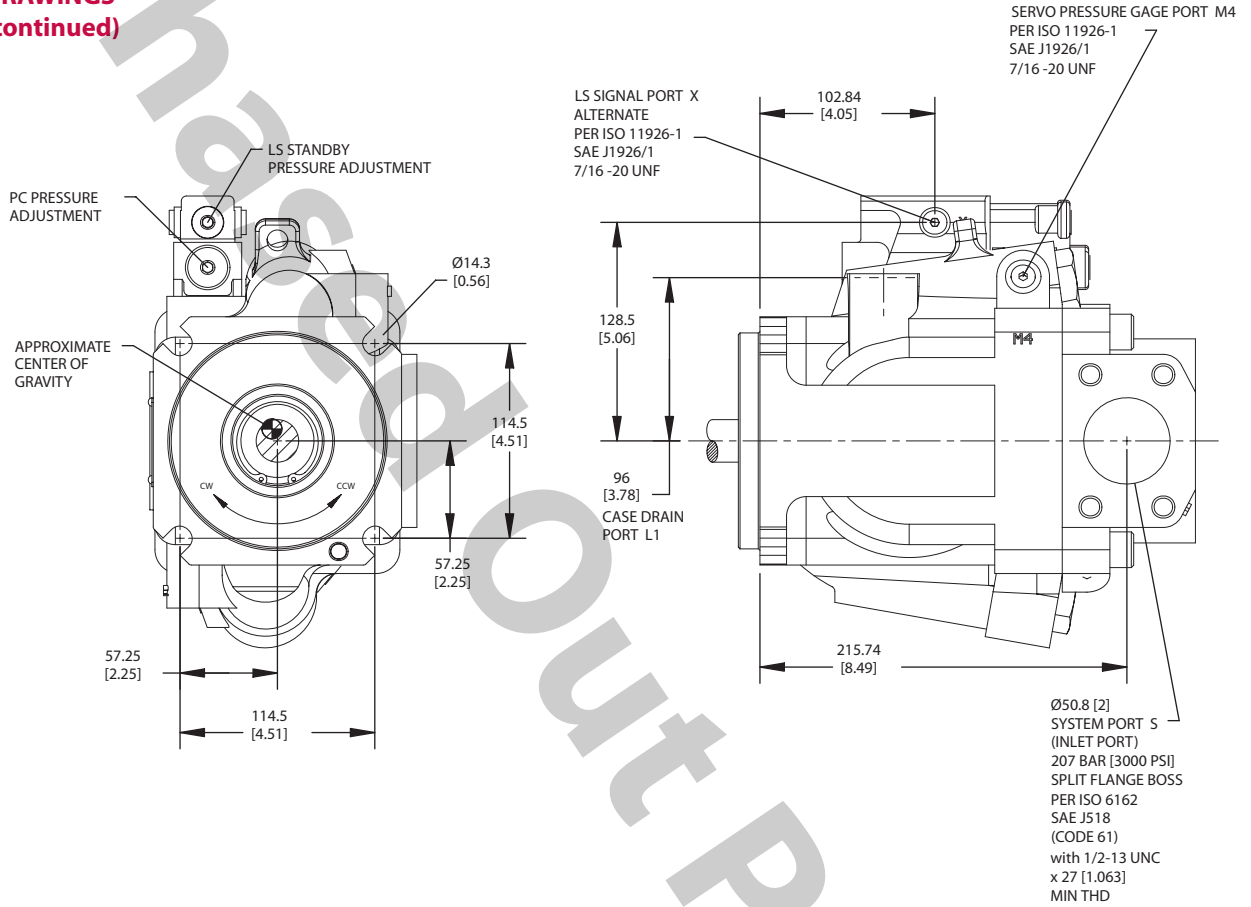

P104 075E





Phase Out Product