

PLUS+1™ MC038-010 Controller

Mobile Machine Management

The MC038-010 is an element of the flexible, powerful, expandable, and affordable PLUS+1 family of mobile machine management products. This device is a general-purpose controller that is equally suited for use as a member of a distributed machine control system, with intelligence in every node, or as a stand-alone controller.

Product Highlights

The MC038-010 employs a Digital Signal Processor (DSP), providing the controller with extremely fast single cycle processing speed and 128K internal flash.

The controller features sleep mode functionality, 6 A digital and PWM, and 10 A PWM output circuits that are powered independently from the DSP. Two of the 10 A outputs can be configured as a bidirectional pair.

Application Development

Users develop MC038-010 applications with PLUS+1 GUIDE. This Microsoft® Windows® based development environment features a user-friendly, field proven, icon-based graphical programming tool, application downloader, and service/diagnostic tool.

Local Address:



PLUS+1™
by SAUER-DANFOSS

MC038-010 Controller

Features

- User-programmable with PLUS+1 GUIDE (Graphical User Integrated Development Environment)
- Power saving sleep mode functionality
- 38 pins: 1 Deutsch® DRC26-38SA connector
- 32 bit fixed-point DSP running at 150 MHz
- 12 bit analog-to-digital converter
- 15 inputs
 - 3 universal (DIN/AIN/FreqIN) that are user-defined as either:
 - Analog:* with configurable ranges 0 to 5.25 Vdc (with over range protection) or 0 to 36 Vdc
 - Digital:* pull up (5 Vdc), pull down (0 Vdc) or pull to center (2.5 Vdc)
 - Frequency (timing):* 1 Hz to 10 kHz
 - 2 digital (DIN) configurable as pull up (5 Vdc), pull down (0 Vdc)
 - 9 digital/analog (DIN/AIN) that are user-defined as either:
 - Digital:* pull up (5 Vdc), pull down (0 Vdc) or pull to center (2.5 Vdc)
 - Analog:* 0 to 5.25 Vdc or 0 to 36 Vdc
 - 1 fixed range analog (AIN/CAN shield) 0 to 5.25 Vdc or CAN shield pin
- 13 outputs
 - 2 DOUT (2 A) configurable as source only
 - 3 HDOUT (6 A) configurable as source only
 - 3 HPWMOUT/DOUT (6 A), configurable as source only
 - 4 HPWMOUT/DOUT (10 A) configurable as source or sink, can be used as bi-directional pairs, (see *Dimensions and Pin Assignments*, back page for pair assignments)
 - 1 HPWMOUT/DOUT (10A) configurable as source only
 - Outputs are powered by three independent power supply pins (see *Dimensions and Pin Assignments*, back page for output pin power supply assignments and maximum allowable current per power supply pin)
 - All PWM outputs operate as open loop. The output is a constant voltage.
- 1 independent ECU power supply, 6 to 36Vdc
- 3 independent power supplies for powering output pins, 9 to 36 Vdc
- 1 CAN 2.0B port. The fixed range analog (AIN/CAN Shield) pin may be configured as a shield pin
- 5 Vdc power supply for external sensors rated at 150 mA, monitored and regulated internally
- 2 LEDs under application software control
- CE compliant

Dimensions and Pin Assignments

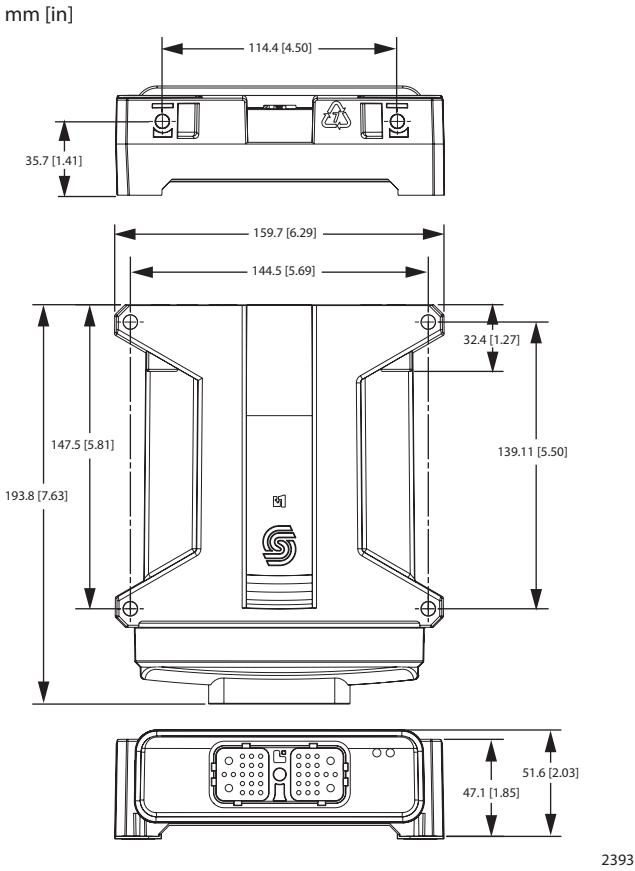

2393

This device is not field serviceable. Opening the device housing voids the warranty.

⚠ Caution

PCB damage may occur. All device power supply + pins must be connected to battery +.

Specifications

Supply voltage, CPU	6 to 36 Vdc
Supply voltage, device	9 to 36 Vdc
Operating temperature, ambient	-40°C to 70°C (-40°F to 158°F)
Storage temperature	-40°C to 85°C (-40°F to 185°F)
Programming temperature	0°C to 70°C (32°F to 158°F)
IP rating (with mating connector attached)	IP 67
EMI/RFI rating	100 V/m
Weight	0.53 kg (1.16 lb)
Vibration	IEC 60068-2-64
Shock	IEC 60068-2-27 test Ea
Device maximum current, sourcing	70 A
Device maximum current, sinking	25 A
Maximum current, power pins: C1-P36, C1-P37, C1-P38	25 A per pin

11051653 • Rev AC • Sep 2009

38 Pin Connector

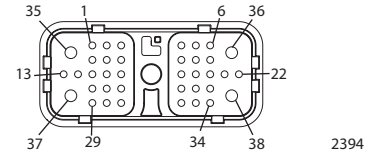

2394

Pin	Controller function	Pin	Controller function
C1-P1	CPU power ground -	C1-P20	DIN/AIN
C1-P2	CPU power supply +	C1-P21	HPWM/DOUT (6A-Pwr = C1-P37, source only)
C1-P3	CAN0+	C1-P22	HPWM/DOUT (10A-Pwr = C1-P37, source only)
C1-P4	CAN0-	C1-P23	DOUT (2A-Pwr = C1-P38, source only)
C1-P5	AIN/CAN shield	C1-P24	DIN/AIN
C1-P6	DIN	C1-P25	DIN/AIN
C1-P7	DIN	C1-P26	DIN/AIN
C1-P8	5 Vdc sensor power +	C1-P27	DIN/AIN
C1-P9	Sensor power ground -	C1-P28	DOUT (2A-Pwr = C1-P38, source only)
C1-P10	DIN/AIN/FreqIN	C1-P29	HPWM/DOUT (10A-Pwr = C1-P36, pair with C1-P34)
C1-P11	DIN/AIN/FreqIN	C1-P30	DOUT (6A-Pwr = C1-P38, source only)
C1-P12	DIN/AIN/FreqIN	C1-P31	DOUT (6A-Pwr = C1-P38, source only)
C1-P13	HPWM/DOUT (10A-Pwr = C1-P37, pair with C1-P15)	C1-P32	HPWM/DOUT (6A-Pwr = C1-P36, source only)
C1-P14	DIN/AIN	C1-P33	HPWM/DOUT (6A-Pwr = C1-P36, source only)
C1-P15	HPWM/DOUT (10A-Pwr = C1-P37, pair with C1-P13)	C1-P34	HPWM/DOUT (10A-Pwr = C1-P36, pair with C1-P29)
C1-P16	HDOUT (6A-Pwr = C1-P38, source only)	C1-P35	Output power ground -
C1-P17	DIN/AIN	C1-P36	Output power supply +
C1-P18	DIN/AIN	C1-P37	Output power supply +
C1-P19	DIN/AIN	C1-P38	Output power supply +

Use care when wiring mating connector.
Above pinouts are for device pins.

Ordering Information

MC038-010 part number	11035917
Related product	Sauer-Danfoss part numbers
CG150 CAN/USB gateway	10104136
Deutsch® mating connector bag assembly	11027919 (16 to 20 AWG)
PLUS+1 GUIDE single user license	10101000

Comprehensive technical information:
PLUS+1 Controller Family Technical Information, 520L0719;
MC038-010 Application Program Interface (API) Document
Sauer-Danfoss product literature on line at:
www.sauer-danfoss.com