

ACQ101A, B Remote Setpoint Modules

BLN-95-8940-2

Issued: July 1991

DESCRIPTION

The ACQ101A and B Remote Setpoint Modules adjust slope to a setpoint other than vertical. When used with the Sauer-Danfoss W894A Proportional Level Controller or R7232 or ACE100A Proportional Indicating Controllers, the slope setpoint can be set anywhere on the infinite resolution scale within 10% of zero slope.

The ACQ101A is hand-held and has a coiled cord and MS Connector for hookup. The ACQ101B is mounted in the cab panel and has a terminal strip for electrical connections.

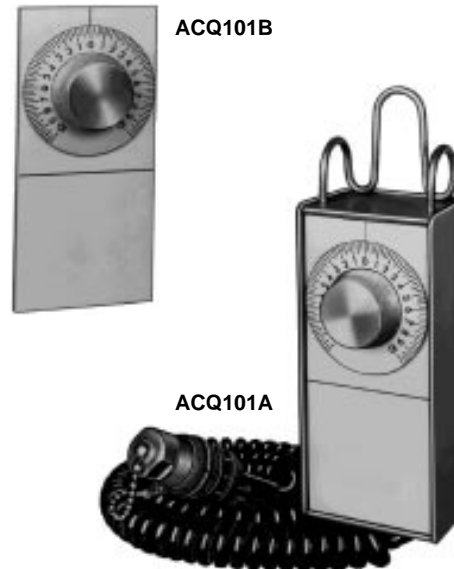

FEATURES

- The ACQ101A hand-held model has a spring-loaded hanger that easily clips to railings, pipes or bars, affording extensive freedom about the machine for the operator.
- The ACQ101 can be rotated in any direction without affecting operation.
- Shock and vibration resistant, both models also resist corrosion and moisture.
- The ACQ101A and B are easy to install. The MS connector on the hand-held model plugs in and screws tight. The panel mount model mounts on a flat surface 3 by 6 inches or larger. Four connections to the terminal strip complete the hookup.

ORDERING INFORMATION

ACCESSORIES

Part Number KW01001 coiled cord assembly extends to 10 feet and provides all necessary wiring connections between the panel-mount ACQ101B and the R7232 Proportional Indicating Controller with MS Connectors or the W894A Proportional Level Controller. It comes completely assembled with MS Connector on one end and spade lugs on the other.

SPECIFY

1. Model Number (ACQ101)
2. Hand-held (A) or Panel-mount (B) version
3. Cable, if needed

TECHNICAL DATA

RESISTANCE

2500 ± 15 ohms between pins A and C of the connector or terminal strip. Resistance between pins A and B increases when the dial is turned clockwise. See the Resistance Vs. Dial Position diagram.

SETPOINT RANGE

Adjustable to ±10.0% slope.

OPERATING TEMPERATURE

0 to 140°F (-18 to +60°C).

STORAGE TEMPERATURE

-40 to +170°F (-40 to +77°C).

WEIGHT

Hand-held model: 1 1/2 lbs. (680 grams).

Panel-mount model: 7 ounces (198 grams).

DIMENSIONS

See the Dimension, Hand-held Model, and Dimensions, Panel-mount Model diagrams.

RESISTANCE VS. DIAL POSITION

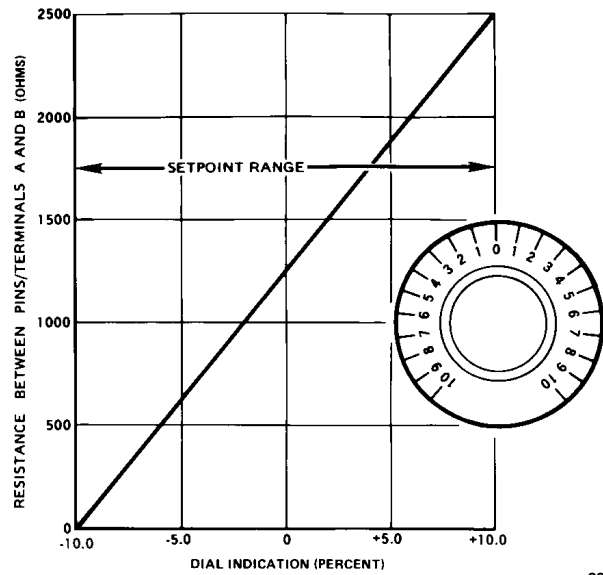

293

Resistance Vs. Dial Position of the ACQ101.

DIMENSIONS, HAND-HELD MODEL

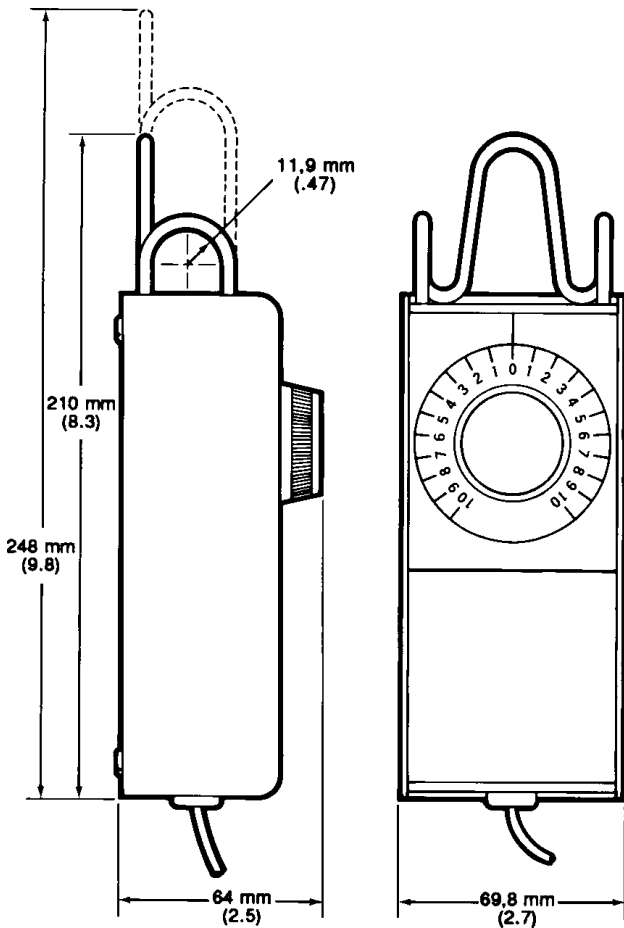

294A

Dimensions of the Hand-Held ACQ101A in Millimeters (Inches).

DIMENSIONS, PANEL-MOUNT MODEL

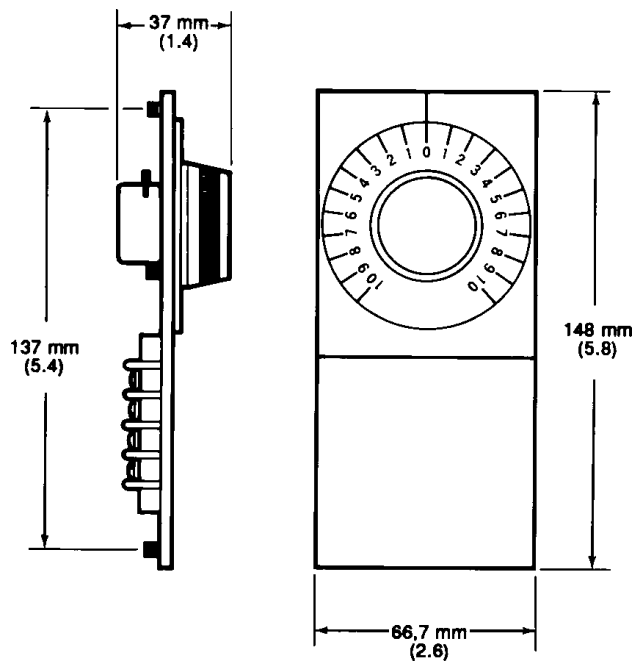

295A

Dimensions of the Panel-Mount ACQ101B in Millimeters (Inches).

ENVIRONMENTAL

SHOCK

Withstands a shock test designed for mobile equipment devices that consists of three shocks of 50 g's and 11 milliseconds duration in both directions of the three major axes for a total of 18 shocks.

VIBRATION

Withstands a vibration test designed for mobile equipment devices that includes two parts:

1. Cycling from 5 to 2000 Hz over a range of ± 1.5 g's to ± 3.0 g's for a period of one hour (if there are four resonant points), for two hours (if there are two or three resonant points), and for three hours (if there is one or no resonant point). The cycling test is performed on each of the three major axes.
2. Resonance dwell for one million cycles over a range of ± 1.5 g's to ± 3.0 g's for each of the four most severe resonant points on each of the three major axes.

MOUNTING

Hand-held models have a spring-return hanger designed for suspending the Remote Setpoint in any convenient location. No mounting is required.

Panel-mount versions require a cutout of the size shown in the Mounting Dimensions diagram. At least one inch of clearance should be provided behind the panel for the ACQ101. Drill 3/16 inch clearance holes in the location shown in the Mounting Dimensions diagram. Remove the nuts from the lugs at the back of the front plate. Insert the lugs through the clearance holes and replace the nuts from the back of the panel.

WIRING

The hand-held models have an integral coiled cord with an MS Connector that plugs directly into the R7232 Proportional Indicating Controller or W894A Proportional Level Controller. If an R7232 Proportional Indicating Controller with terminal strips is to be used in conjunction with the hand-held ACQ101A, mount a Bendix Type Number MS3102A16S-8P (Sauer-Sundstrand Part Number K03992) receptacle on a panel and wire the receptacle to the corresponding letters on the R7232 terminal strip.

Wiring for the panel-mount ACQ101B is shown in the Wiring Diagram. The ACQ101B has terminal strips for wiring connections. If an R7232 Proportional Indicating Controller with MS Connectors or W894A Proportional Level Controller is to be used in conjunction with the ACQ101B, order Part Number KW01001 cable assembly. The cable assembly includes spade lugs at one end and an MS Connector at the other end to provide all wiring for the panel-mount model.

MOUNTING DIMENSIONS

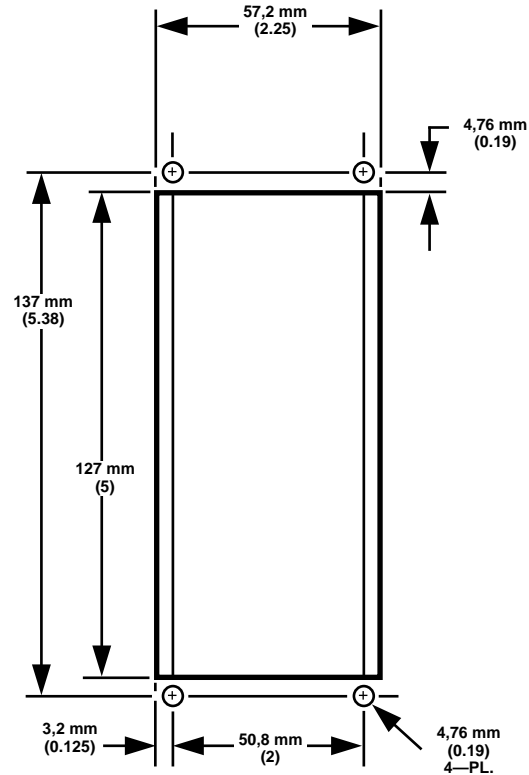

200A

Mounting Dimensions for the ACQ101B Panel-Mount Model.

TROUBLESHOOTING

The ACQ101 Remote Setpoint will provide extended trouble-free operation and should not need servicing under normal operating conditions. Be sure the ACQ101 is malfunctioning before replacing it.

1. Check the wiring. Connector or spade lugs may have been disconnected. Check all wires, look for cuts or evidence of pinching.

2. Check for continuity. If a VOM is available, check resistance between pins/terminals A and C for 2500 ohms. Check continuity between pins/terminals A and B, B and C while rotating the dial. Resistance should approximate the values shown in the Resistance Vs. Dial Position diagram.

TROUBLESHOOTING *(continued)*

- If another ACQ101 is available, connect it in place of the existing one. Change the slope setpoint and observe the operation. If the replacement ACQ101 corrects the malfunction, replace the original unit.
- Check the operation of the servovalve, proportional indicating controller and sensor.

WIRING DIAGRAM

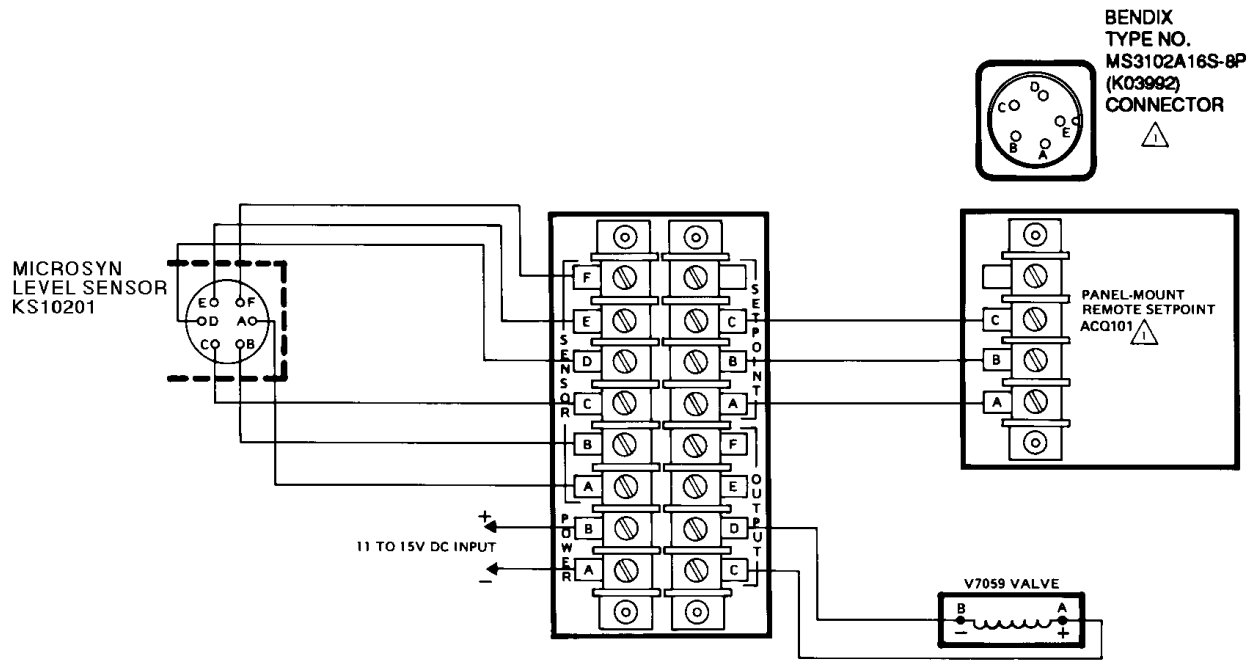

⚠ IF A HAND-HELD REMOTE SETPOINT ACQ101A IS USED, CONNECT THE PROPORTIONAL INDICATING CONTROLLER TO A BENDIX TYPE NO. MS3102A-16S-8P. A, B, C TO A, B, C RESPECTIVELY AND MOUNT ON THE PANEL.

385A

Typical System Wiring to an R7232 With Terminal Strips.

CUSTOMER SERVICE

NORTH AMERICA

ORDER FROM

Sauer-Danfoss (US) Company
Customer Service Department
3500 Annapolis Lane North
Minneapolis, Minnesota 55447
Phone: (763) 509-2084
Fax: (7632) 559-0108

DEVICE REPAIR

For devices in need of repair or evaluation, include a description of the problem and what work you believe needs to be done, along with your name, address and telephone number.

RETURN TO

Sauer-Danfoss (US) Company
Return Goods Department
3500 Annapolis Lane North
Minneapolis, Minnesota 55447

EUROPE

ORDER FROM

Sauer-Danfoss (Neumünster) GmbH & Co.
Order Entry Department
Krokamp 35
Postfach 2460
D-24531 Neumünster
Germany
Phone: 49-4321-8710
Fax: 49-4321-871-184