

W894A Proportional Level Controller

BLN-95-8974-5

Issued: March 1992

DESCRIPTION

The W894A Proportional Level Controller provides automatic slope control of paving, curbing, grading and similar mobile equipment. The Controller measures deviation from a gravity reference and supplies a two-wire output for driving a servovalve such as the MCV113. The W894A operates in 12 Volt electrical systems.

Two modules are housed in the case of the Controller with plug-in electrical interconnections. The transducer sensing module electromagnetically measures the deviation of the equipment it is mounted on from a gravity reference. The amplifier module accepts the signals from the slope sensing module and uses the deviation to provide a corrective output to keep the equipment at the prescribed slope.



FEATURES

- Rugged aluminum housing
- Adjustable sensitivity
- RUN/STANDBY switch permits operator to switch to manual control
- Deviation meter with zero center shows deviation from setpoint in RUN or STANDBY positions
- Reverse polarity and short circuit protection
- Moisture and corrosion resistant
- Accepts a remote slope setpoint adjuster
- Withstands vibration and shock

ORDERING INFORMATION

SPECIFY

1. Model Number W894A. See Table A.
2. Accessories

TABLE A.

ORDER NUMBER	DESCRIPTION
W894A1053	12Vdc, Drives MCV113 Hot Side Switching

ACCESSORIES

Order the necessary parts from the list below:

1. MCV113 Servovalve
2. Q625A Remote Setpoint (hand-held setpoint with integral coiled cord and MS connector).
3. Q625A Remote Setpoint (panel-mount setpoint with terminal strip).
4. KW01001 Cable (two-foot coiled cable that extends to ten feet. Has straight connector on one end and spade lugs on the other. Mates with the five-pin W894A connector and the panel-mount Q625A Remote Setpoint)
5. KW01013 Cable (two-foot coiled cable that extends to ten feet. Has right angle connector on one end and straight connector on the other. Mates with the ten-pin W894A connector and an MS3102A18-1P plug).
6. KW01012 Cable (four-foot coiled cable that extends to twenty feet. Has right angle connector on one end and straight connector on the other. Mates with the ten-pin W894A connector and an MS3102A18-1P plug).

TECHNICAL DATA

ELECTRICAL

INPUT VOLTAGE
11 to 15 Vdc

POWER CONSUMPTION
4.5 watts maximum

OUTPUT VOLTAGE
5.4 to 6.2 Vdc with a 12 Vdc input into a 32 ohm load. A null meter reading at the red/white division indicates a 3 Vdc output.

PROPORTIONAL GAIN
With gain potentiometer set to maximum, gain will be 1.7 to 2.7 Vdc per 0.3% slope error input.

BLOCK DIAGRAM

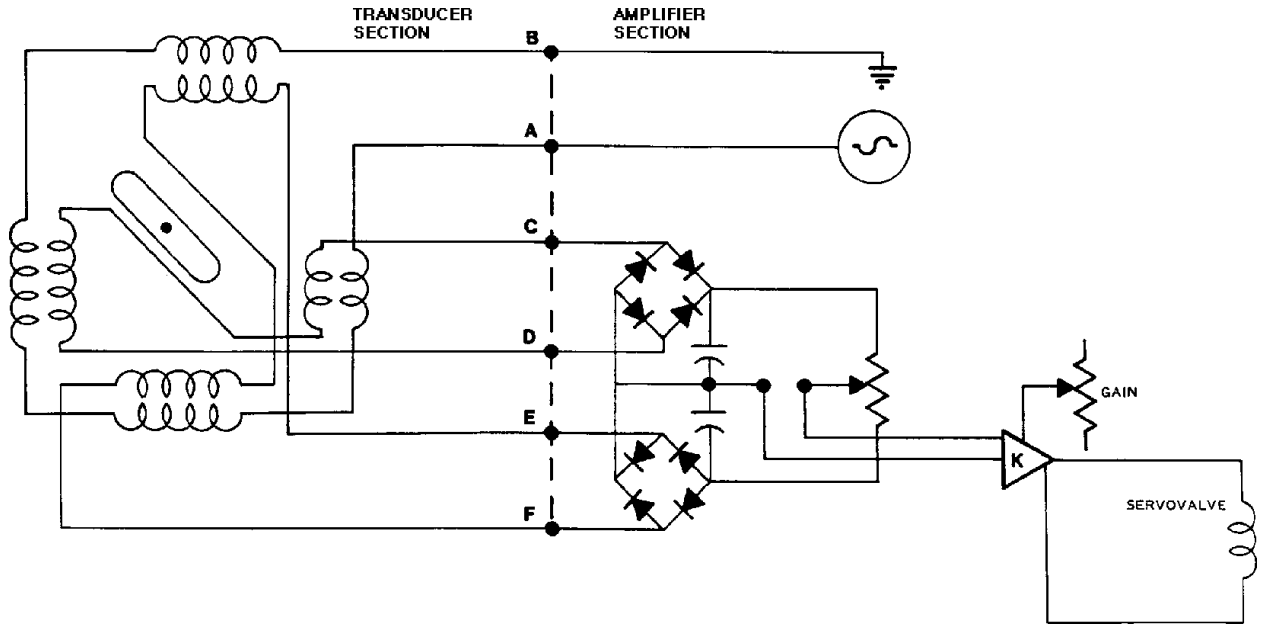

1183

Schematic of Transducer and Amplifier Sections of the W894A.

CONNECTION DIAGRAM

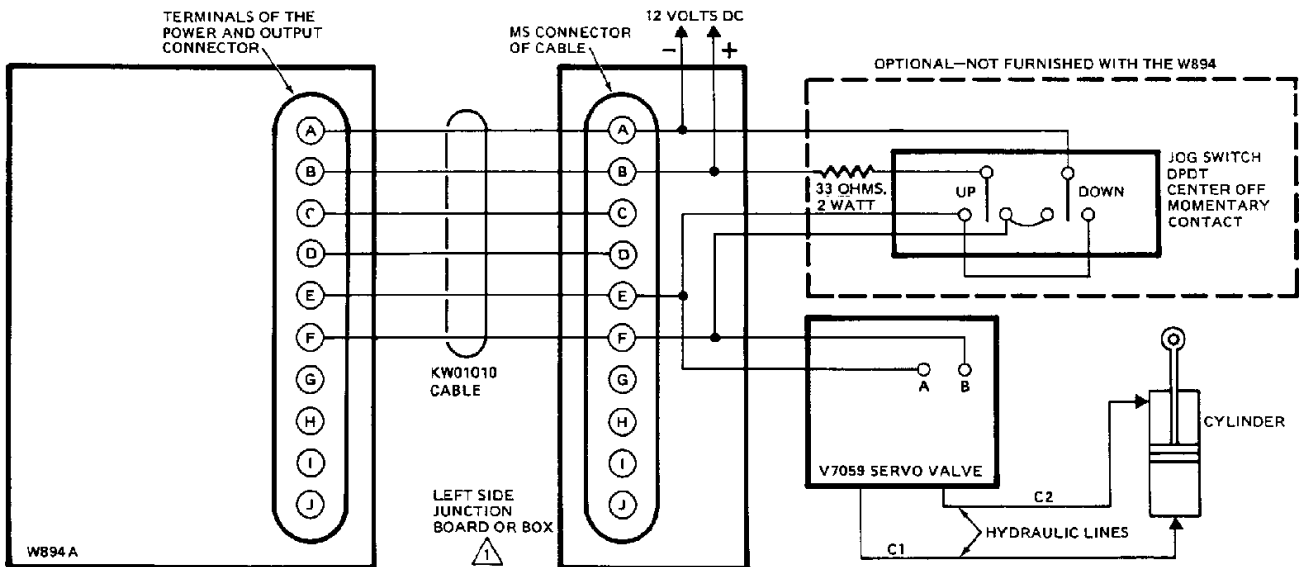

⚠️ WIRING OF THE RIGHT SIDE OF THE MACHINE IS IDENTICAL WITH EXCEPTION TO THE MCV113 SERVOVALVE WHERE POLARITY IS REVERSED.

Typical System Connections.

206C

DIMENSIONS

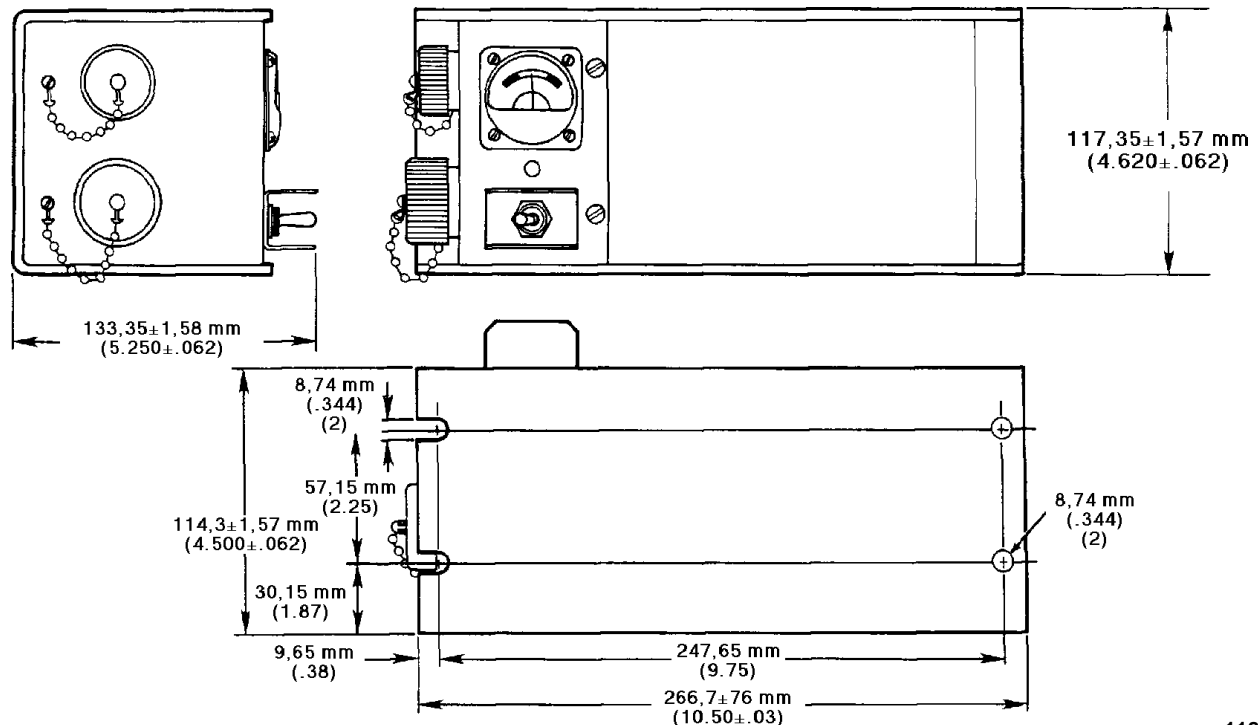

1182

Dimensions of the W894A in Millimeters (Inches).

THEORY OF OPERATION

The amplifier section of the W894A supplies an excitation of 1.4 V-ac (440 Hz square wave) across Pins A and B of the W894A's internal MS connector to the transducer. See the Block Diagram. As the machine is tilted off the proper slope, the rotor rotates with respect to the secondary coils. As the rotor moves toward one secondary and away from the other, the voltage induced in the coil toward the rotor is increased, the opposite being true of the other secondary. At the full 10%-from-null slope (the rated maximum range), the voltage across the secondary closer to the rotor is 5.3 V-ac, while the other voltage is 4.2 V-ac.

The ac signals from the secondaries are applied to two bridge rectifiers in the amplifier section, where each is converted to dc. At null the voltages across both capacitors are equal. When a change in secondary voltage is introduced, the voltages across the capacitors are offset, inducing a differential between the reference (which may be a remote setpoint command) and the junction between the capacitors. This differential serves as the positive or negative correction signal that is amplified and then supplied to the servovalves to close the control loop. Control action drives the machine to a position such that the sensor error signal to the amplifier section is reduced to null.

ENVIRONMENTAL

OPERATING TEMPERATURE
-18° to 77° C (0° to 170° F)

STORAGE TEMPERATURE
-40° to 77° C (-40° to 170° F)

HUMIDITY
After being placed in a controlled atmosphere of 95% humidity at 49° C (120° F) for 10 days, the W894A will perform within specification limits.

RAIN
After being showered from all directions by a high pressure hose down, the W894A will perform within specification limits. This test fulfills NEMA 4 specifications.

VIBRATION
Withstands a vibration test designed for mobile equipment consisting of two parts:

1. Cycling from 5 to 2000 Hz in each of the 3 axes.
2. Resonance dwell for one million cycles for each resonance point in each of the 3 axes.

SHOCK
50 g's for 11 milliseconds. Three shocks in both directions of the 3 mutually perpendicular axes for a total of 18 shocks.

WEIGHT
3.4 Kg (7 pounds, 8 ounces)

DIMENSIONS
See the Dimension Drawing.

CUSTOMER SERVICE

NORTH AMERICA

ORDER FROM

Sauer-Danfoss (US) Company
Customer Service Department
3500 Annapolis Lane North
Minneapolis, Minnesota 55447
Phone: (763) 509-2084
Fax: (763) 559-0108

DEVICE REPAIR

For devices in need of repair or evaluation, include a description of the problem and what work you believe needs to be done, along with your name, address and telephone number.

RETURN TO

Sauer-Danfoss (US) Company
Return Goods Department
3500 Annapolis Lane North
Minneapolis, Minnesota 55447

EUROPE

ORDER FROM

Sauer-Danfoss (Neumünster) GmbH & Co.
Order Entry Department
Krokamp 35
Postfach 2460
D-24531 Neumünster
Germany
Phone: 49-4321-8710
Fax: 49-4321-871-184