

# KE03 DC Position/Level Amplifier

BLN-95-9012-1

Issued: August 1998

## DESCRIPTION

The KE03 amplifier will accept millivolt dc signal and drive a two-wire torque motor bidirectionally proportional to the magnitude and polarity of an input signal. A regulated dc voltage is provided for sensor excitation.

For mobile applications, the sensor detects deviations in the position of the machine with respect to a reference (i.e., gravity, stringline, etc.). The amplifier converts the deviation information into a proportional output to drive a servovalve such as the MCV113. The servovalve repositions the final drive element in the proper direction to eliminate the error signal. In steering control applications a feedback sensor, such as an MCX103, may also be needed to protect against over-correction.

## TECHNICAL DATA

### OPERATING VOLTAGE

11-V to 15-V

### POWER CONSUMPTION

0.5-amp maximum

### VOLTAGE OUTPUT

0 to  $5.8 \pm 0.04$ -V with 12-Vdc supply voltage and a 33-ohm, 0.5 heavy load 440  $\pm$  40-Hz pulse width modulation

### SENSOR VOLTAGE

The amplifier provides 6-Vdc to a potentiometer sensor such as the ACX104B. Inputs to the amplifier KE03101 run at a common mode of 3-V. If the ACX104B is at center

with 6-V applied, the resultant 3-V input will balance the amplifier. Another amplifier version, the KE03102, runs at a common mode of 5-Vdc.

### GAIN ADJUSTMENTS

A  $\pm 35$ -mVdc error signal will result in full output to a servovalve with maximum gain.

With minimum gain a  $\pm 1$ -V signal is required for full output.

### ELECTRICAL CONNECTION

12-pin Elco Varicon connector 0.20-inch center

### MATING CONNECTOR

Sauer-Sundstrand part number K01519

## THEORY OF OPERATION

The input stage accepts a millivolt signal from the external sensor(s). The sensor voltage is compared to a reference voltage, and the difference is amplified. In the amplifier stage the dc error signal is summed with a variable amplitude 400-Hz signal, creating a dynamic balance between the two halves of the time proportional output (power stage). An increased gain setting reduces the amount of error signal required to supply full drive to the valve.

The amplifier output goes to the power drive stage, creating a pulse width output. The output signal provides both dither and drive current to the load at a rate of 440-Hz. With zero error signal, the drive in each direction will be equal, resulting in no net power delivered to the valve. With the introduction of an error signal, the drive in one direction will be on longer than the other, resulting in net power delivered to the valve.

# BLOCK DIAGRAM

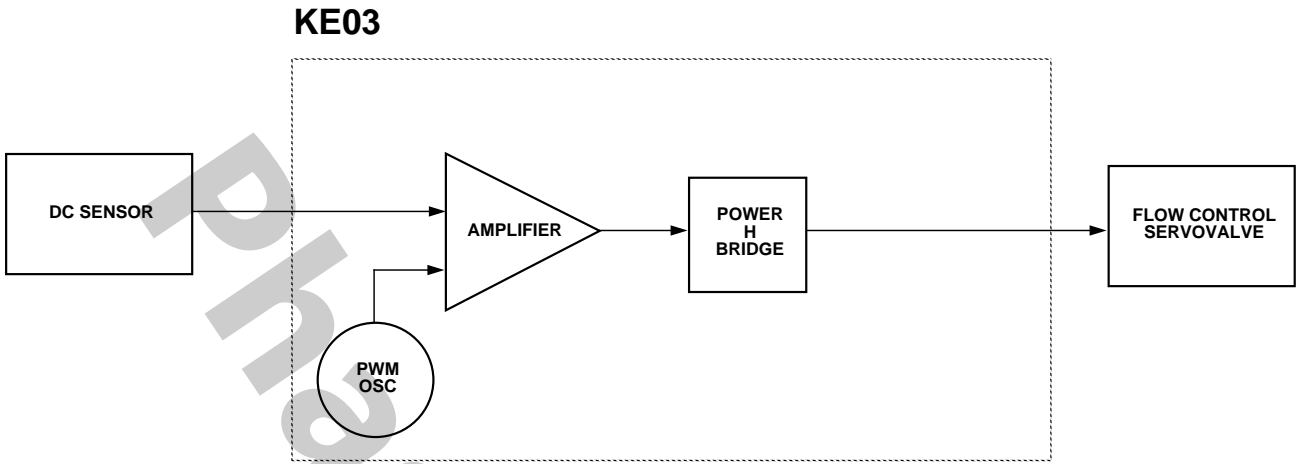

1631

# CONNECTION DIAGRAM

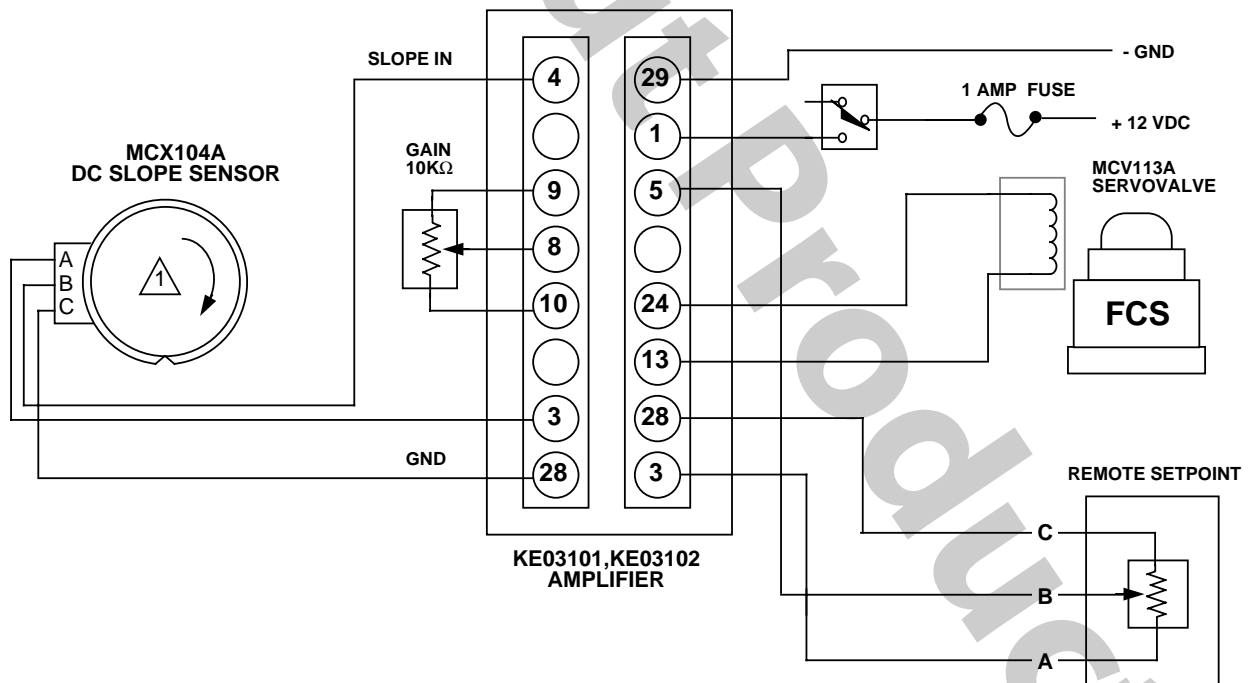

 CLOCKWISE SENSOR ROTATION (VIEWED FROM REAR) GIVES (+) OUTPUT ON F WITH RESPECT TO E

1633

# MOUNTING DIMENSIONS

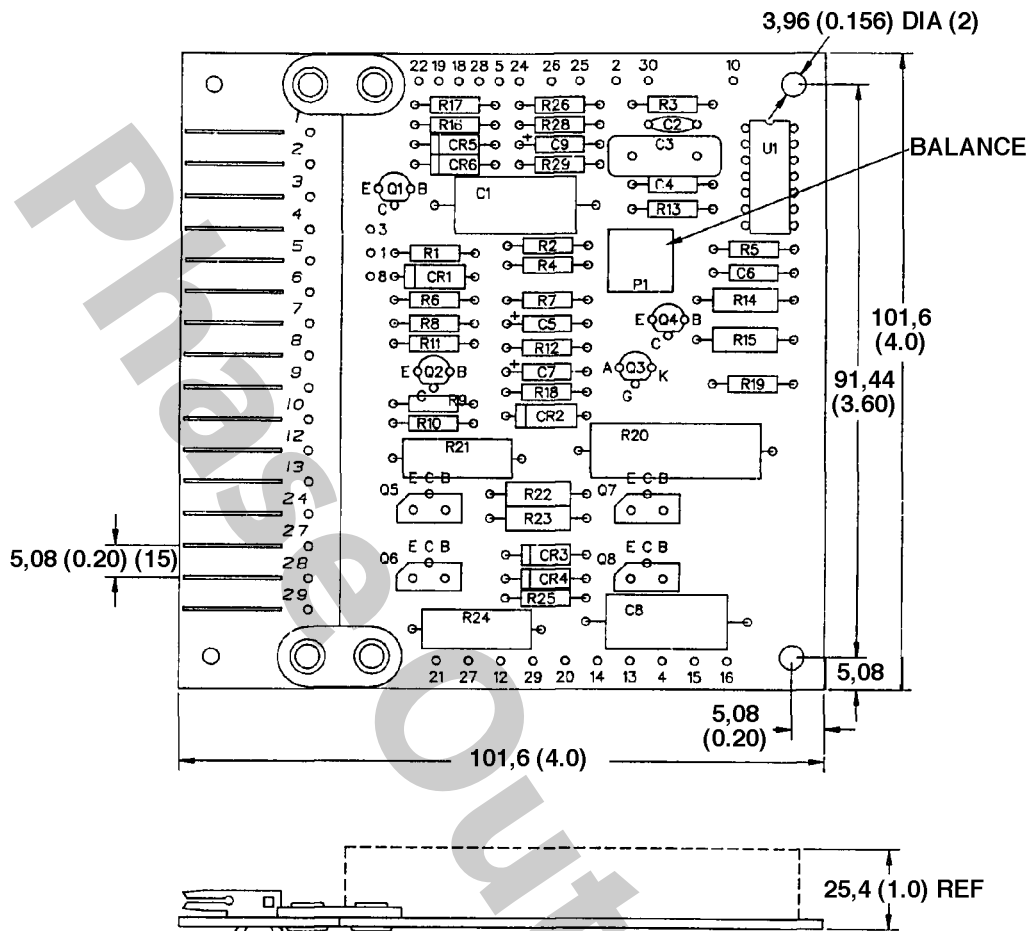

Dimensions of the KE03 in Millimeters (Inches).

1632

## CUSTOMER SERVICE

### NORTH AMERICA

#### ORDER FROM

Sauer-Danfoss (US) Company  
 Customer Service Department  
 3500 Annapolis Lane North  
 Minneapolis, Minnesota 55447  
 Phone: (763) 509-2084  
 Fax: (763) 559-0108

#### DEVICE REPAIR

For devices in need of repair or evaluation, include a description of the problem and what work you believe needs to be done, along with your name, address and telephone number.

#### RETURN TO

Sauer-Danfoss (US) Company  
 Return Goods Department  
 3500 Annapolis Lane North  
 Minneapolis, Minnesota 55447

### EUROPE

#### ORDER FROM

Sauer-Danfoss (Neumünster) GmbH & Co.  
 Order Entry Department  
 Krokamp 35  
 Postfach 2460  
 D-24531 Neumünster  
 Germany  
 Phone: 49-4321-8710  
 Fax: 49-4321-8711355