

SX Microcontroller

BLN-95-9067-2

Issue: October 2002

DESCRIPTION

Sauer-Danfoss SX microcontroller is an environmentally hardened device that is an ideal platform for mobile machine software applications such as hydrostatic transmission automotive control, closed loop speed control, engine load control, and leader-follower control.

The SX consists of a circuit board assembly inside a rugged die-cast zinc housing. The controller can interface with a wide variety of input devices including potentiometers, Hall-effect sensors, pressure sensors, pulse pickups and encoders, and has output options that interface with high current proportional solenoid valves and low current pressure control pilot valves.

Standard, preprogrammed application solution software, called SauerPersonalities, make the SX a cost effective solution for OEMs looking to replace analog controls or to introduce micro electronic controls on their machines. SauerPersonalities are available for most common machine control applications, isolating OEMs from the need to write application software code. SauerPersonalities are readily tailored to specific machines by changing application tuning parameters through the use of Sauer-Danfoss WebGPI graphical set-up software.



FEATURES

- Robust electronics operates over a range of 9 to 32 volts with reverse battery, negative transient and load dump protection
- Environmentally hardened design including coated die cast zinc housing that withstands harsh mobile machine operating conditions including shock, vibration EMI/RFI, high pressure washdown, temperature and humidity extremes
- Compact footprint
- Motorola 8 bit MCH68HC908 microprocessor
- Versatile I / O—Hardware configurable inputs and outputs
- Standard Sauer-Danfoss (4) LED configuration for diagnostics
- EEPROM memory allows factory shipment of pre-programmed SauerPersonalities or field programming of engineered application software and tuning parameters
- SauerKernel operating system facilitates application software transportability across Sauer-Danfoss micro electronic platforms
- WebGPI user interface
- Optional CAN 2.0b-compatible network communication

APPLICATION SOFTWARE

SX is designed to run SauerPersonalities or control solution software engineered for a specific machine. Consult Sauer-

Danfoss Minneapolis Customer Service for a list of available SauerPersonalities.

ORDERING AND REPAIR INFORMATION

The SX ordering part number designates both hardware and application software. The software component includes both application software (SauerPersonalities or Engineered) and tuning parameters associated with the application. For complete product ordering information, including part number, consult Sauer-Danfoss Minneapolis Customer Service.

The SX is not repairable and must be replaced if a failure occurs. Consult Sauer-Danfoss Minneapolis Customer Service for replacement part information.

RELATED LITERATURE

UNIT SPECIFICATION SHEETS

Unit specification sheets are specific to SX part numbers. Each unit specification sheet includes SX hardware I/O configuration, installation and pinout information.

SAUERPERSONALITY USER'S MANUALS

Each SauerPersonality User's Manual includes necessary information required to apply, start-up and provide diagnostic support for a specific personality.

TECHNICAL DATA

POWER SUPPLY

9-32 Vdc
Power consumption: 2 W (With Digital and Valve Outputs Off)

SENSOR POWER SUPPLY

Internal 5 Vdc regulator for external sensor power (0.03 A, max)

COMMUNICATION

RS232
(Optional) CAN, 2.0b compliant

LEDs

- (1) green system power indicator
- (1) green 5 Vdc sensor power indicator
- (1) yellow mode indicator (software configurable)
- (1) red status indicator (software configurable)

CONNECTOR

18 pin Metri-Pack connector

MATING CONNECTOR BAG ASSEMBLY

Sauer-Sundstrand part number K23334

ENVIRONMENTAL

OPERATING TEMPERATURE

-40° C to + 70° C

MOISTURE

Protected against 95% relative humidity, high pressure wash downs and salt spray

VIBRATION

12 Gs swept sine, 0.765 octave/min in the range of 10 Hz to 2 KHz, 24 hours per axis in three axes

SHOCK

50 Gs for 11 ms waveform in all three axes for a total of 18 shocks

EMI/RFI

100 V/M in range of 1 MHz to 1 GHz

INPUTS

(3) GENERAL PURPOSE SWITCHING DIGITAL INPUTS

Hardware configurable to be switch to ground or switch to batt+
Input resistance: 15 Kohm ($\pm 5\%$)
Pull-up resistance: 15 Kohm ($\pm 5\%$)

(2) 0 TO 5 VDC GENERAL PURPOSE ANALOG INPUTS 8 bit resolution

(1) 0 TO 5 VDC ANALOG OR TIMING INPUT

Hardware configurable to be PPU input or analog input
If configured as a PPU input, can be biased to +5 Vdc or to ground
Count frequency: 1 to 6000 HZ
Compatible with variable reluctance or active open collector PPU powered by 12 V or 24 V system

(1) 0 TO 5 VDC ANALOG OR TIMING INPUT OR CAN SHIELD

Hardware configurable
If configured as a PPU input, can be biased to + 5 Vdc or to ground
Count frequency: 1 to 6000 Hz
Compatible with variable reluctance or active open collector PPU powered by 12 V or 24 V system

OUTPUTS

(2) HIGH SIDE PROPORTIONAL PWM VALVE DRIVERS WITH INTERNAL CURRENT FEEDBACK (2A MAX) Feedback sample resistor is hardware configurable

(1) HIGH CURRENT DIGITAL OUTPUT (2A MAX)

DIMENSIONS

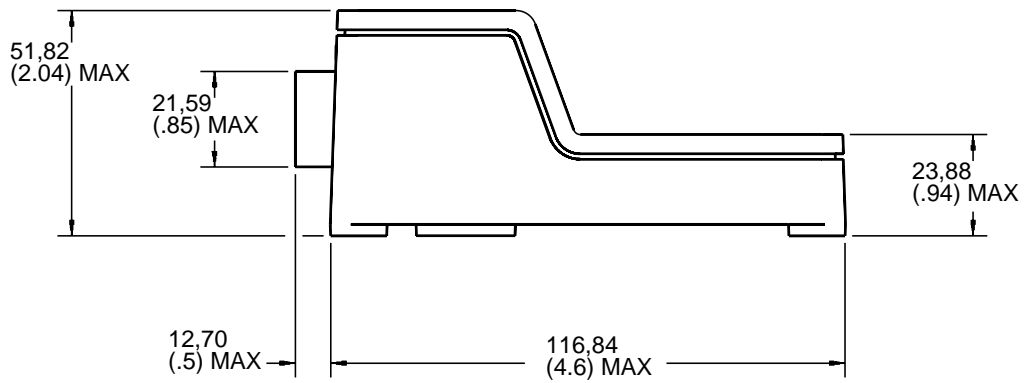
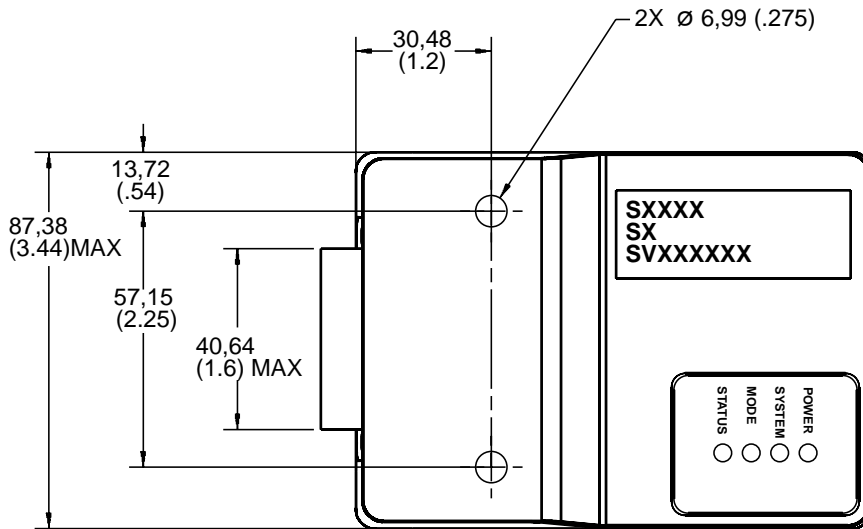

3009

Dimensions of the SX Microcontroller in Millimeters (Inches).

CONNECTOR PINOUTS

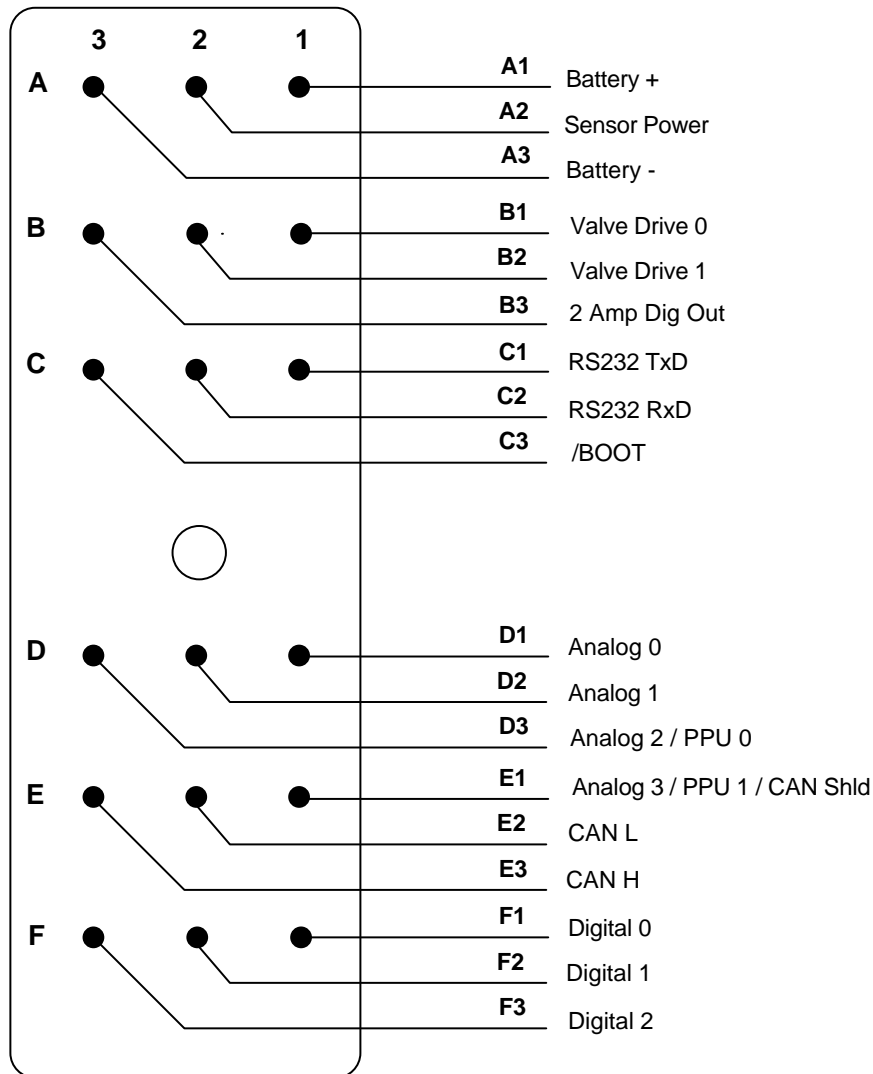

3008

MACHINE WIRING GUIDELINES

- All wires must be protected from mechanical abuse. Wire can be run in flexible metal or plastic conduits.
- Use 85°C wire with abrasion resistant insulation. 105°C wire should be considered near hot surfaces.
- Use 18 AWG wire.
- Separate high current wires such as solenoids, lights, alternators or fuel pumps from control wires.
- Run wires along the inside of, or close to, metal machine frame surfaces where possible. This simulates a shield which will minimize the effects of EMI/RFI radiation.
- Do not run wires near sharp metal corners. Consider running the wire through a grommet when rounding a corner.
- Do not run wires near hot machine members.
- Provide strain relief for all wires.
- Avoid running wires near moving or vibrating components.
- Avoid long, unsupported wire spans.
- All sensors and valve drive circuits have dedicated wired power sources and ground returns. They should be used.
- Sensor lines should be twisted about one turn every 10 cm (4 inches).
- It is better to use wire harness anchors that will allow wires to float with respect to the machine frame rather than rigid anchors.

CUSTOMER SERVICE

NORTH AMERICA

ORDER FROM

Sauer-Danfoss (US) Company
Customer Service Department
3500 Annapolis Lane North
Minneapolis, Minnesota 55447
Phone: (763) 509-2084
Fax: (763) 559-0108

EUROPE

ORDER FROM

Sauer-Danfoss (Neumünster) GmbH & Co.
Order Entry Department
Krokamp 35
Postfach 2460
D-24531 Neumünster
Germany
Phone: 49-4321-8710
Fax: 49-4321-871355