

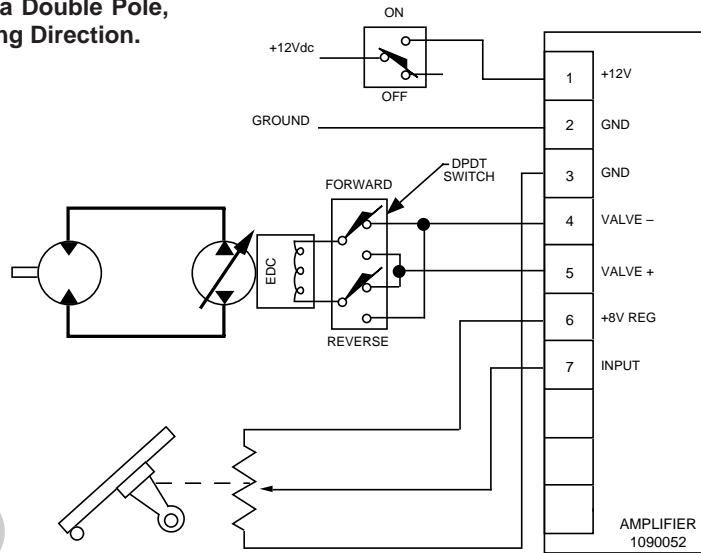

# TYPICAL WIRING CONNECTIONS

Controlling a Single Coil EDC Requires a Double Pole, Double Throw (DPDT) Switch for Changing Direction.



1706

Controlling a Dual Coil EDC Requires a Single Pole, Double Throw (SPDT) Switch for Changing Direction. Also, Just One Coil of a Dual Coil can be Wired and Switched as in Above Diagram.

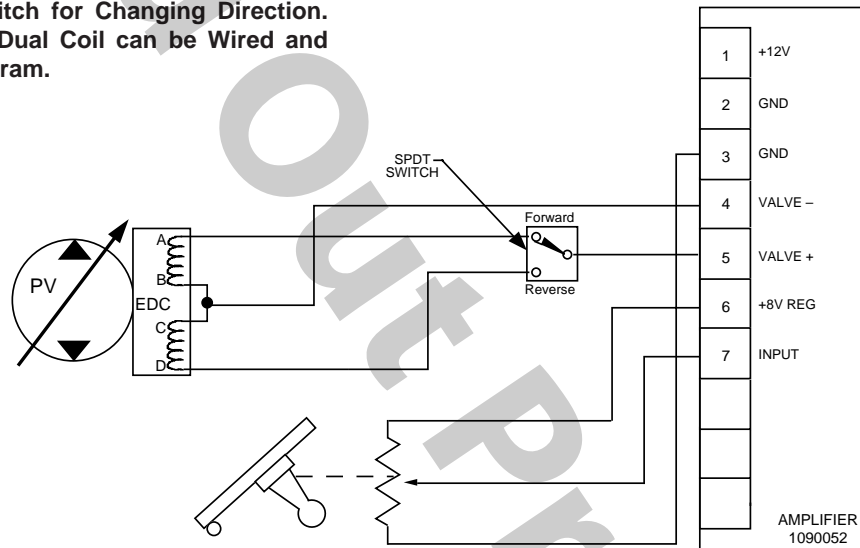

1993

When Controlling Two or Three EDCs, They must be Wired Coils in Series/EDCs in Parallel as Shown in Diagram Below. A Double Pole, Double Throw (DPDT) Switch is Used for Changing Flow Direction of the PV.

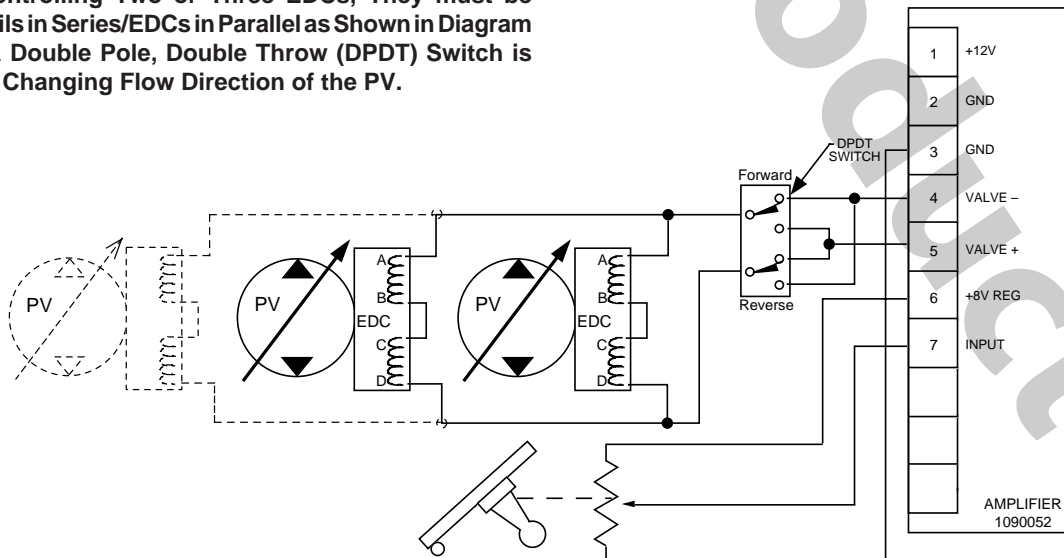

1994